

SEE FRONT ELEVATION BELOW

VIEW OF TWO LEVEL BIRDHOUSE

ROOF DETAILS

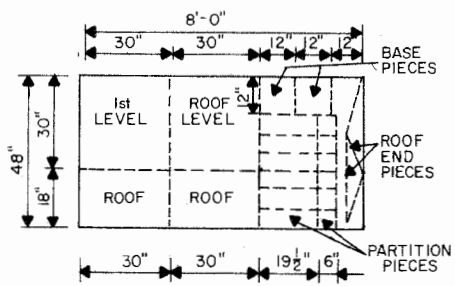
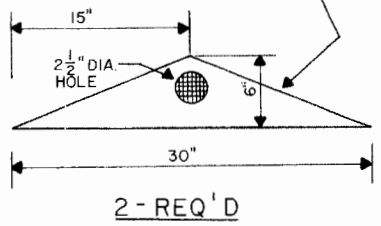

PLYWOOD CUTTING DIAGRAM FOR ONE LEVEL BIRDHOUSE

0" 1" 4" 9" 12" SCALE 1/8"=1"
UNLESS OTHERWISE NOTED

3/8" EXT. TYPE PLYWOOD
12" 6" 0" 1" 2" 3" SCALE 3/8"=1'-0"

NOTE: TO FASTEN PARTITIONS SLOT PLYWOOD, GLUE, OR USE MOULDING

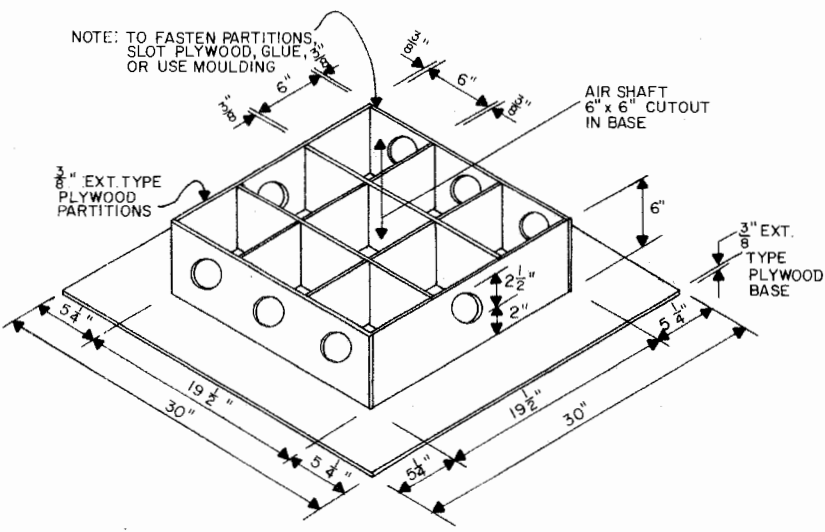

DETAILS OF ONE LEVEL

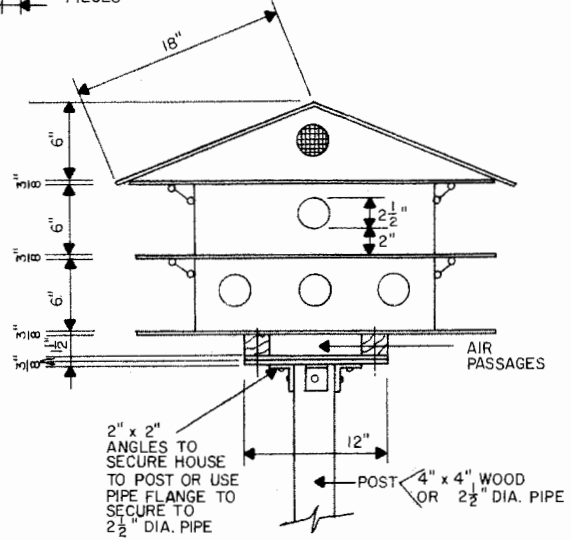

NOTE 1. LOCATE NEAR AREA NEEDING INSECT CONTROL.
2. HEIGHT ABOVE GROUND IS 15'-20'.

FRONT ELEVATION

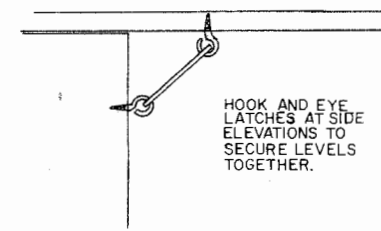

DETAIL FOR LATCHES

LSU
AgCenter
Research & Extension

PURPLE MARTIN BIRDHOUSE

NJ' 69	EX. 6344	SHEET OF
--------	----------	------------

Disclaimer

This site makes available conceptual plans that can be helpful in developing building layouts and selecting equipment for various agricultural applications. These plans do not necessarily represent the most current technology or construction codes. They are not construction plans and do not replace the need for competent design assistance in developing safe, legal and well-functioning agricultural building system. The LSU Agriculture Center, the Mid-West Plan Service, the United States Department of Agriculture and none of the cooperating land-grant universities warranty these plans.