

LIGHTWEIGHT ALUM.
OR STIFF PLASTIC FLAP
W/LEATHER OR CANVAS
HINGES, PER NOTE 5

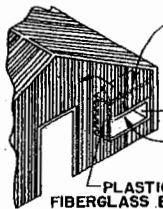

PLASTIC OR
FIBERGLASS ENCLOSURE
INSIDE HOUSE, OPENING
AT BOTTOM TO OUTSIDE
FOR FRESH AIR INLET.

GRAVITY - FLAP
FRESH AIR INLET
PER NOTE 5

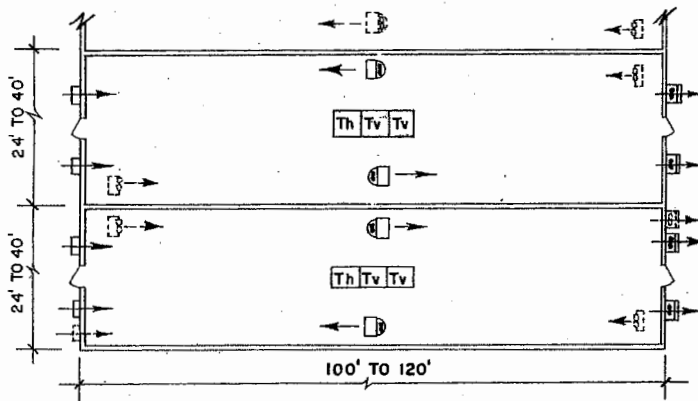
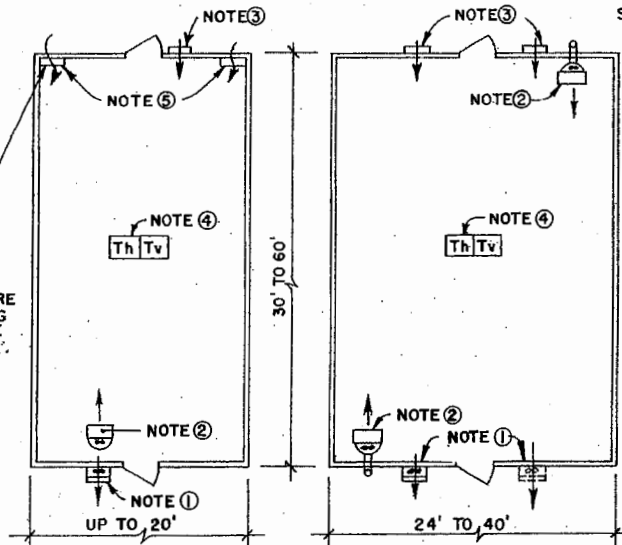

RIDGE & FURROW
SCALE: NONE

NOTES ON EQUIPMENT

1. Single - or two-speed exhaust fan(s) with gravity shutter mounted above or beside door, or on side for small houses.
2. Unit heater supported by pipe framework anchored in ground, or suspended from roof structure as shown by installation diagram, sheet 2.
3. Motorized fresh air inlet shutter(s) mounted above door, or in endwall. Deflector baffle shown by installation diagram, sheet 2, may be used on first shutter that opens in winter to deflect air upward for mixing and prevent cold drafts on plants. Shutters same size as fans of Note 1.
4. Heat and ventilation control thermostats mounted near center of house at ground bed, bench, or eye-level depending on crop and zone of temperature sensing desired. (NOTE: Mercury bulb types to be rightly mounted and leveled for accurate operation.)
5. Gravity-flap air inlet sized for 1sq. ft./800 C.F.M. See diagram for construction. For the larger house, build these inlets for 1/2 of total fan C.F.M. and use a motorized inlet shutter for remaining C.F.M.
6. Use propeller-type circulation fans of 2,000-3,000 C.F.M., free-delivery, suspended approximately 6' high for air circulation.

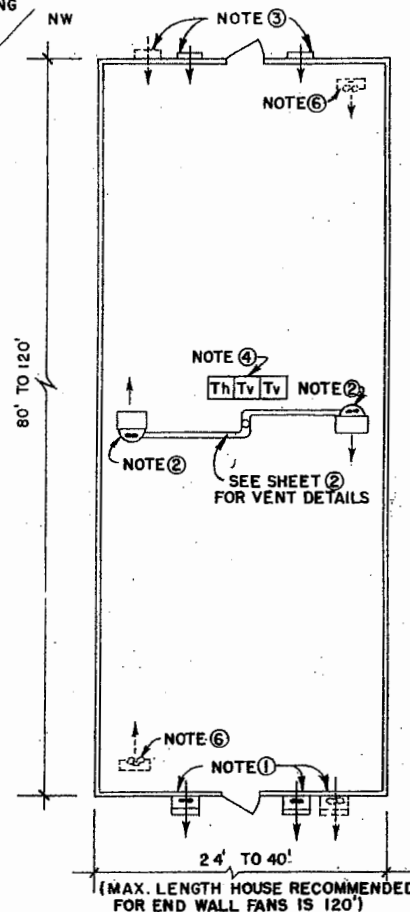

EQUIPMENT LEGEND

- VENTILATION FANS; EXHAUST FLOW, WITH GRAVITY SHUTTERS, WALL MOUNTED
- ALTERNATE OR ADDITIONAL LOCATION OF VENTILATION FAN(S)
- MOTORIZED FRESH AIR INLET SHUTTER(S).
- OPTIONAL CIRCULATION FANS FOR INCREASED AIR CIRCULATION.
- UNIT HEATER (GAS OR OIL-FIRE VENTED TYPE, OR HOT WATER OR STEAM FIN/COILED TYPE)
- HEAT CONTROL THERMOSTAT(S)
- VENTILATION CONTROL THERMOSTAT(S)

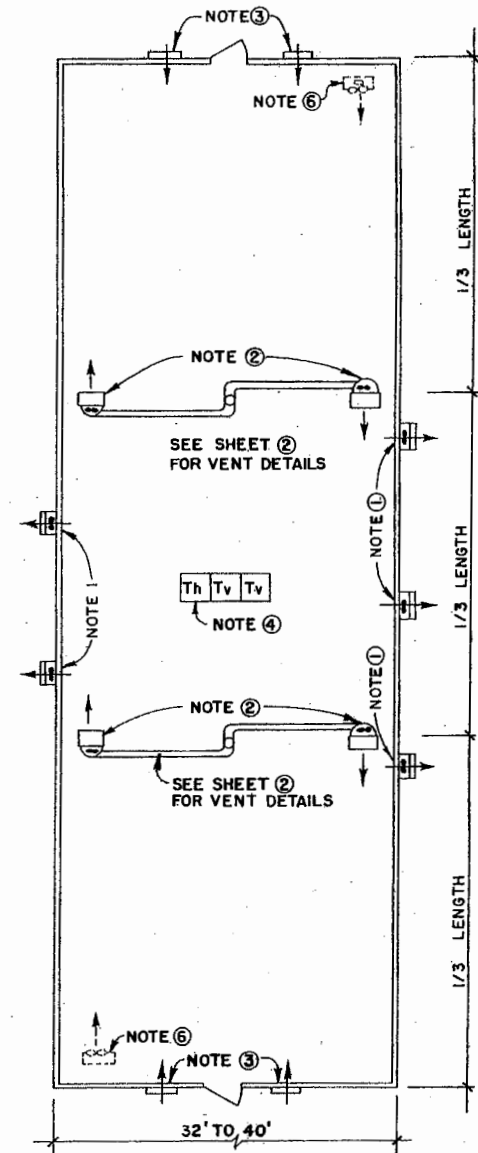

EQUIPMENT LAYOUT FOR VARIOUS SIZE HOUSES

SELECT LAYOUT SUITABLE FOR YOUR HOUSE

BASED ON: UNIV. OF KY. PLAN NO. 11.811-7



GREENHOUSE HEATING
AND VENTILATING SYSTEMS

KY '75 6197 SHEET 1 OF 3

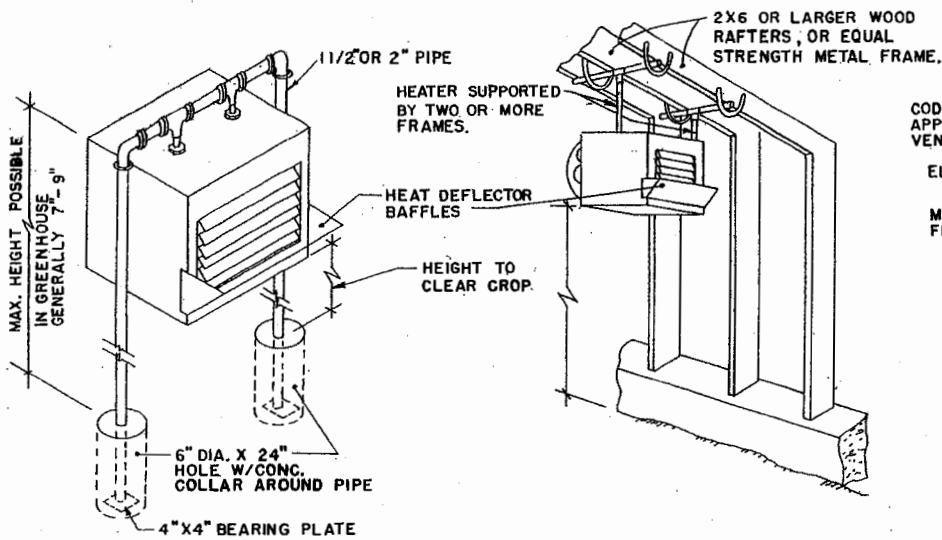

PIPE FRAME IN GROUND

HEATER HUNG FROM GREENHOUSE ROOF

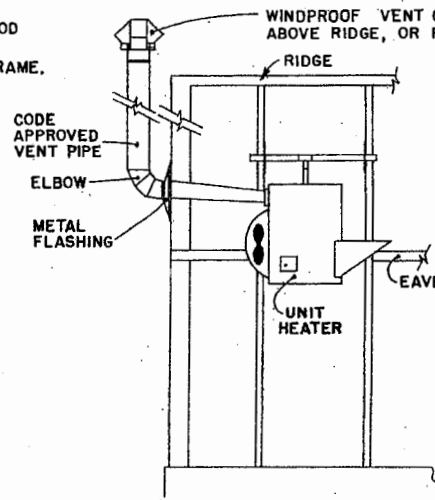

FLUE VENT THRU END WALL

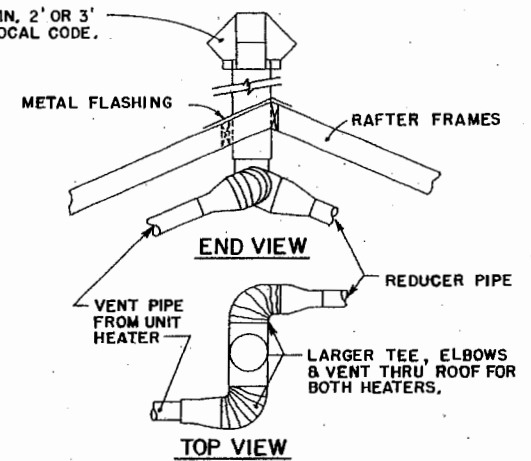

COMMON VENT THRU ROOF AT RIDGE

(NOTE: INDIVIDUAL VENTS MAY BE USED AT EACH HEATER IF DESIRED)

UNIT HEATER INSTALLATION DETAILS
NO SCALE

NOTE: PLYWOOD OR BOARDS FOR FRAME.

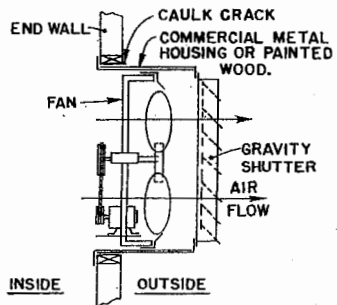

FAN EXTENDS OUTSIDE BUILDING

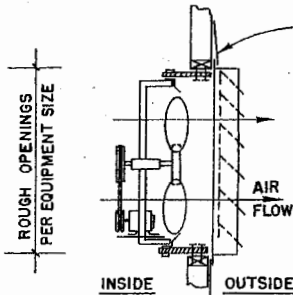

FAN EXTENDS INSIDE BUILDING

(FOR MIN. WINTER CONDENSATION WITHIN HOUSING)

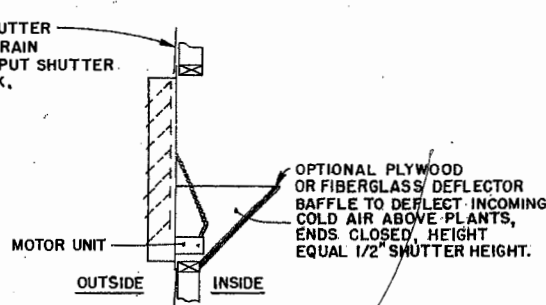

MOTORIZED AIR INLET SHUTTER

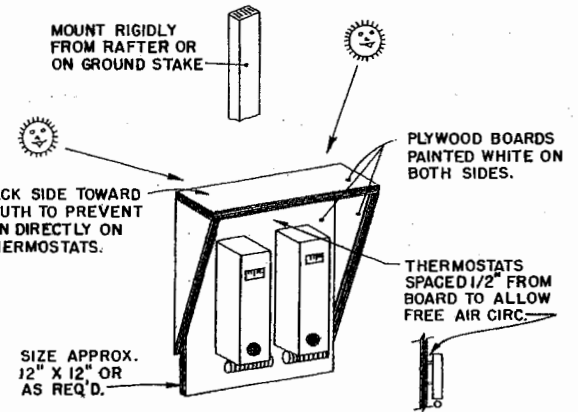

THERMOSTAT MOUNTING BOARD

FAN & SHUTTER INSTALLATION DETAILS
NO SCALE

LSU AgCenter <small>Research & Extension</small>		
GREENHOUSE HEATING AND VENTILATING SYSTEM		
KY. '75	6197	SHEET 2 OF 3

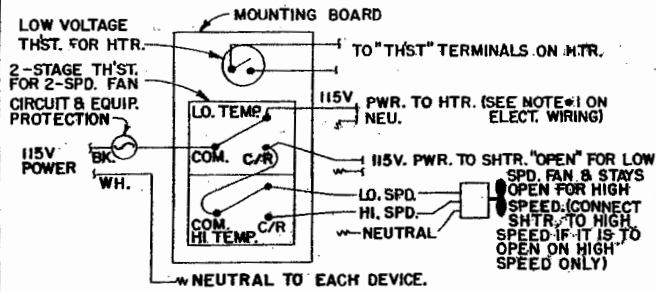

WIRING DIAGRAM FOR:

- 1-2- SPEED FAN.
- 1- MOTORIZED SHUTTER.
- 1-2- STAGE TH'ST. FOR FAN.
- 1- HEATER THERMOSTAT.

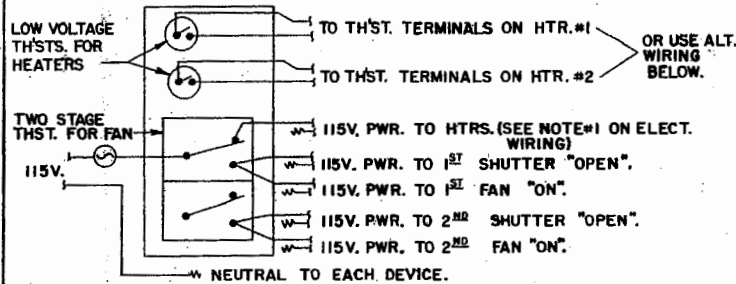

WIRING DIAGRAM FOR:

- 2- SINGLE SPEED FANS.
- 2- MOTORIZED SHUTTERS.
- 1- 2- STAGE TH'ST. (OR 2-SPEED TH'STS.)
- 2- HEATER THERMOSTAT.

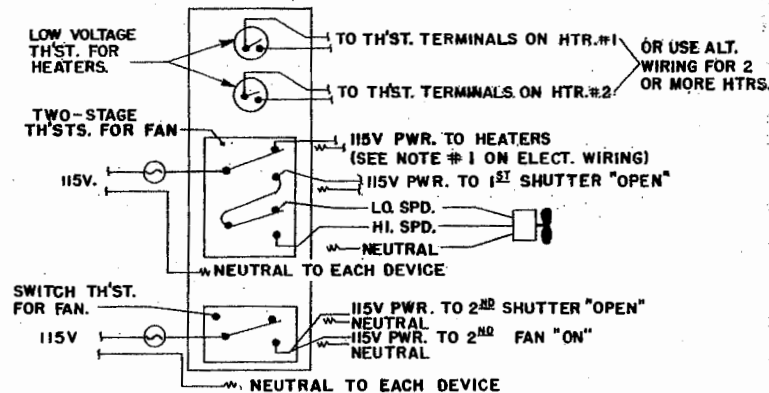

WIRING DIAGRAM FOR:

- 1- TWO SPEED FAN.
- 1- OR MORE - SINGLE SPEED FAN(S).
- 2- OR MORE - MOTORIZED SHUTTERS.
- 2- OR MORE - UNIT HEATERS.
- 2- HEAT TH'ST. (OR USE ALTERNATE WIRING AT RIGHT.)
- 1- TWO-STAGE TH'ST. FOR TWO-SPEED FAN.
- 1- OR MORE - SWITCH TYPE TH'ST. FOR FAN(S).

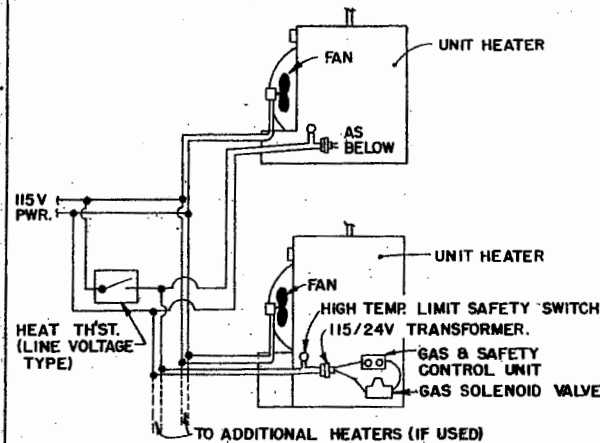

ALTERNATE UNIT HEATER WIRING FOR:

- 1. ONE THERMOSTAT ONLY FOR HEAT CONTROL.
- 2. FANS RUNNING CONTINUOUSLY FOR AIR CIRCUIT.
- 3. HEAT CAN'T BE "ON" UNLESS FANS ARE POWERED.
- 4. ALL OTHER SAFETY CONTROLS AS IN NORMAL OPERATION.

GENERAL INFORMATION

1. Total fan ventilation capacity to be based on 3/4 to 1 air change per minute for plastic houses or fiber glass covered with removable plastic sides during the summer. For totally enclosed houses, use 1 to 1 1/4 air change per minute. See Ky.811-5 for chart of ventilation requirements for various house sizes. First stage of winter ventilation should be 25 to 35 percent of house volume (C.F.M.) with at least 2 more stages to reach maximum rate.
2. All fans to be mounted in end or side of house to exhaust with (not against) air flow of prevailing winds. Mount fresh air inlet shutters in opposite end, or side.
3. Heat requirements to be based on house type and size, type of covering, number of layers, and temperature differential to be maintained. See Ky.11.811-4 for chart of heat requirements for greenhouses. Select size and number of unit heaters to give total heat output required.
4. Wire heater fans to operate continuously in winter to provide air circulation. Use manual switch or proper THST. connections to stop operation during summer ventilation.
5. When two or more heaters are used in one house, recommend all heaters be connected to one thermostat through a small multi-pole relay or use the alternate wiring diagram shown so all heaters will operate together for a more uniform house temperature. (CAUTION: Two or more heater THST. TERMINALS cannot be connected directly on same SPST thermostat to operate properly, thus, the relay or alternate wiring is required.) Where individual thermostats are used for each heater, set them to operate as close to same temperature as possible for the most uniform house temperature.
6. Use optional booster fans or commercial poly-tube equipment to increase air circulation if unit heater fans are inadequate.
7. Evaporative pad cooling may be used with any plan shown. Install and use according to manufacturer's instructions. Be sure to obtain data and information on the water requirements, installation procedures, performance capacities, maintenance, costs, and feasibility for your use before purchasing pad cooling.

NOTES ON ELECTRICAL WIRING

1. Heat and ventilation fans wired as shown prevent operation at same time.
2. Set HEAT TH'STS. at minimum temp. desired in greenhouse.
3. Set FAN TH'STS. at temperature desired for ventilation to begin, but at least 5°F above HEAT TH'ST. setting.
4. Be sure total amperage of fan motors and other equipment connected to a TH'ST. does not exceed allowable load rating of TH'ST. contacts. If necessary, use proper power relays or motor contactors to handle required load. (CAUTION: Two separate relays are required to operate a 2-speed fan; thus, use 2-speed motors within amperage rating of a 2-stage THST.

ELECTRICAL WIRING DIAGRAMS

NO SCALE



GREENHOUSE HEATING AND VENTILATING SYSTEMS

KY '75 6197 SHEET 3 OF 3

Disclaimer

This site makes available conceptual plans that can be helpful in developing building layouts and selecting equipment for various agricultural applications. These plans do not necessarily represent the most current technology or construction codes. They are not construction plans and do not replace the need for competent design assistance in developing safe, legal and well-functioning agricultural building system. The LSU Agriculture Center, the Mid-West Plan Service, the United States Department of Agriculture and none of the cooperating land-grant universities warranty these plans.