

NOTE: SEE DETAIL "C", SHEET 2 OF 2 FOR ADDITIONAL ENDWALL CONSTRUCTION INFORMATION.

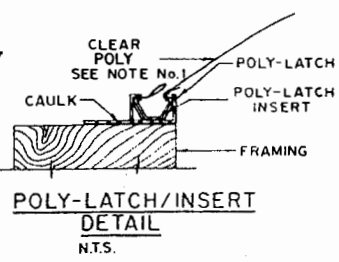

LOW COST SOLAR COLLECTOR FOR GRAIN DRYER

| | | |
|--------|------|--------------|
| FL '80 | 6341 | SHEET 1 OF 2 |
|--------|------|--------------|

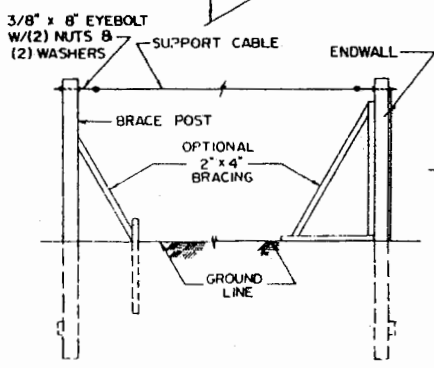
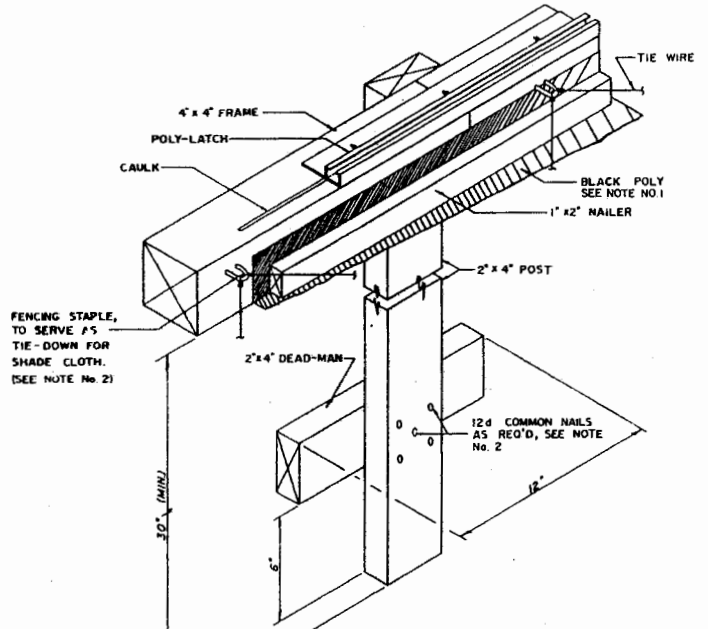
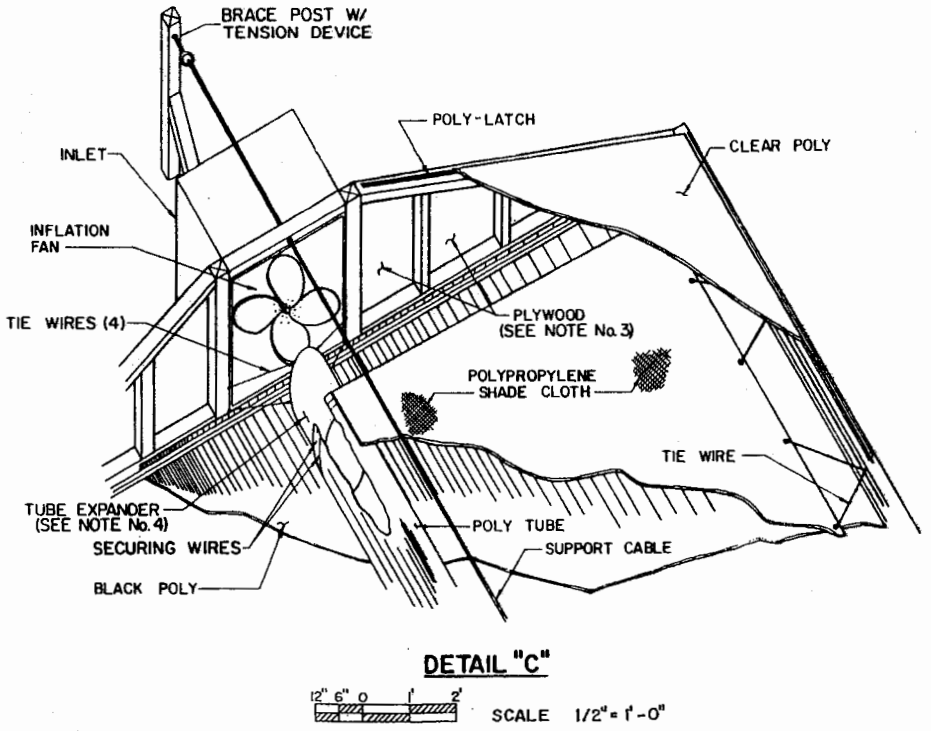
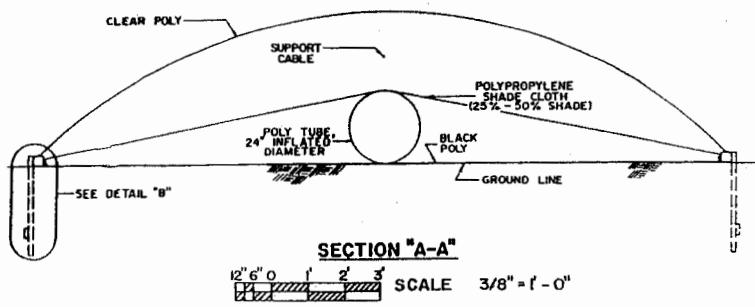

NOTES:

1. ALL POLY SHALL BE FOLDED AS TO PROVIDE DOUBLE THICKNESS AT POINTS OF ATTACHMENT.
2. ALL NAILS AND STAPLES SHALL BE HOT-DIP GALVANIZED.
3. PLYWOOD SHALL BE GLUED AND NAILED TO PROVIDE SEAL.
4. TUBE EXPANDER MAY BE ANY CIRCULAR ITEM HAVING A 24" DIAMETER. PURPOSE IS TO HOLD THE MOUTH OF THE POLY TUBE OPEN FOR INFLATION.
5. ALL BUTT JOINTS ON FRAMING SHALL BE CAULKED OR OTHERWISE SEALED.
6. ALL 4"x4" FRAMING JOINTS SHALL BE AT CENTER-LINE OF POSTS. SEE DETAIL "B" THIS SHEET.
7. ALL FRAMING, BRACES AND POSTS SHALL BE NEW PRESSURE TREATED LUMBER.
8. ALL PLYWOOD SHALL BE 1/2", EXTERIOR GRADE.
9. DUE TO POOR SOIL CONDITIONS, OPTIONAL BRACING MAY BE DESIRED.

| BILL OF MATERIALS | | |
|-------------------|----------|---|
| ITEM No. | QUANT. | DESCRIPTION |
| 1. | 29 | 4"x4" P.T., 8' LENGTH (FRAMING) |
| * 2. | 4 | 4"x4" P.T., 6' LENGTH (POSTS) |
| 3. | 8 | 2"x4" P.T., 12' LENGTH (ENDWALLS BRACING & FRAMING) |
| 4. | 9 | 2"x4" P.T., 12' LENGTH (POSTS & DEADMEN) |
| 5. | 232L.F. | 1"x2" P.T., (NAILER STRIP) |
| 6. | 4 | 4"x8"x1/2" EXTERIOR PLYWOOD |
| 7. | 240L.F. | POLY-LATCH W/INSERT (CAVE ENTERPRISES, INC. OR EQUAL) |
| 8. | 100L.F. | 24" WIDE, 6 mil BLACK POLYETHYLENE |
| 9. | 94L.F. | 18" WIDE SHADE CLOTH (25%-50% SHADE W/ GROMMETS at 2' O.C.) |
| 10. | 96L.F. | 24" DIAMETER POLY-TUBE |
| 11. | 100L.F. | 24" WIDE, 6 mil CLEAR POLYETHYLENE (MONSANTO 603 OR EQUAL) |
| 12. | 110 L.F. | 1/8" DIAMETER TENSION CABLE (PLASTIC COATED) |
| 13. | 2 | 3/8" EYEBOLT, 8" W/EXTRA THREAD |
| 14. | 220L.F. | TIE WIRE, SIZE AS REQUIRED |
| 15. | As Req'd | 12d COMMON NAILS (SEE NOTE No. 2) |
| 16. | As Req'd | 8d COMMON NAILS (SEE NOTE No. 2) |
| 17. | As Req'd | 1-1/2"(MIN.) FENCE STAPLES (SEE NOTE No. 2) |
| 18. | As Req'd | No. 8 WOOD SCREWS 1-1/4" LENGTH |
| * 20. | 1 | 4"x4" PT., 6' LENGTH (OPTIONAL BRACE) |

LSU
AgCenter
ANIMALS & EQUIPMENT

LOW COST SOLAR COLLECTOR FOR GRAIN DRYER

| | | |
|---------|------|--------------|
| FL '80 | 6341 | SHEET 2 OF 2 |
| REV '88 | | |

Disclaimer

This site makes available conceptual plans that can be helpful in developing building layouts and selecting equipment for various agricultural applications. These plans do not necessarily represent the most current technology or construction codes. They are not construction plans and do not replace the need for competent design assistance in developing safe, legal and well-functioning agricultural building system. The LSU Agriculture Center, the Mid-West Plan Service, the United States Department of Agriculture and none of the cooperating land-grant universities warranty these plans.