

THIS SET OF PLANS SHOWS THREE ARRANGEMENTS FOR USING FREE STALL HOUSING IN A CONFINEMENT SYSTEM. YOUR LOCAL MILK MARKET AUTHORITIES SHOULD BE CONSULTED FOR COMPLIANCE WITH SANITARY REGULATIONS BEFORE BEGINNING CONSTRUCTION.

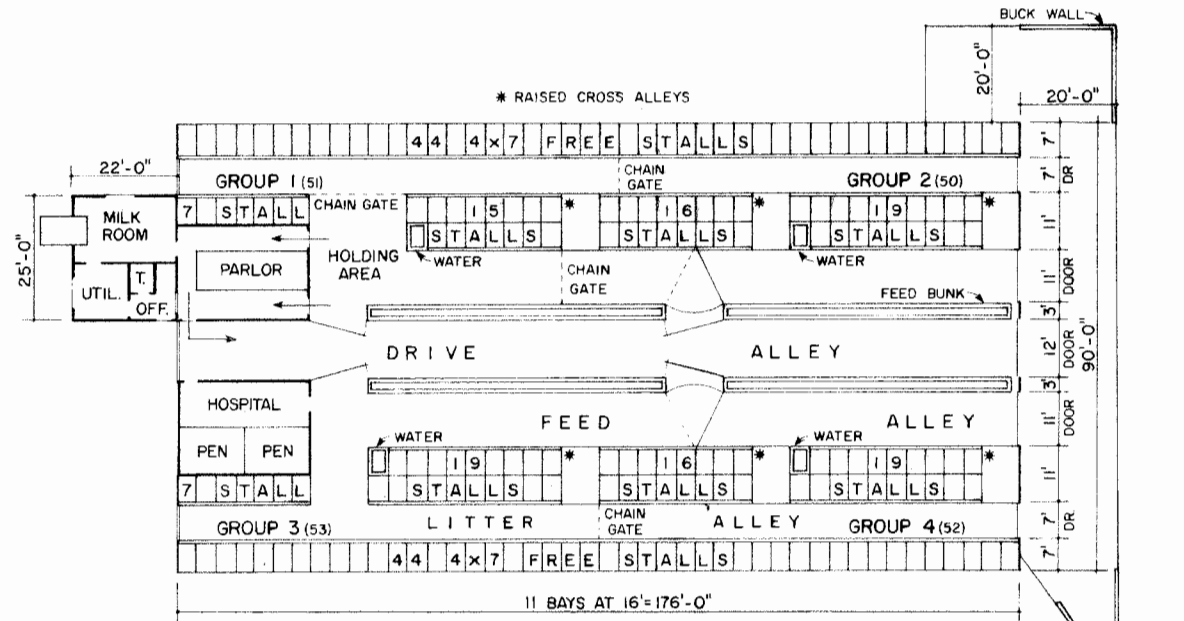

**SYSTEM 1: 4 GROUPS**  
 PARLOR IN MAIN BARN NO  
 SEPARATE HOLDING AREA  
 206 STALLS

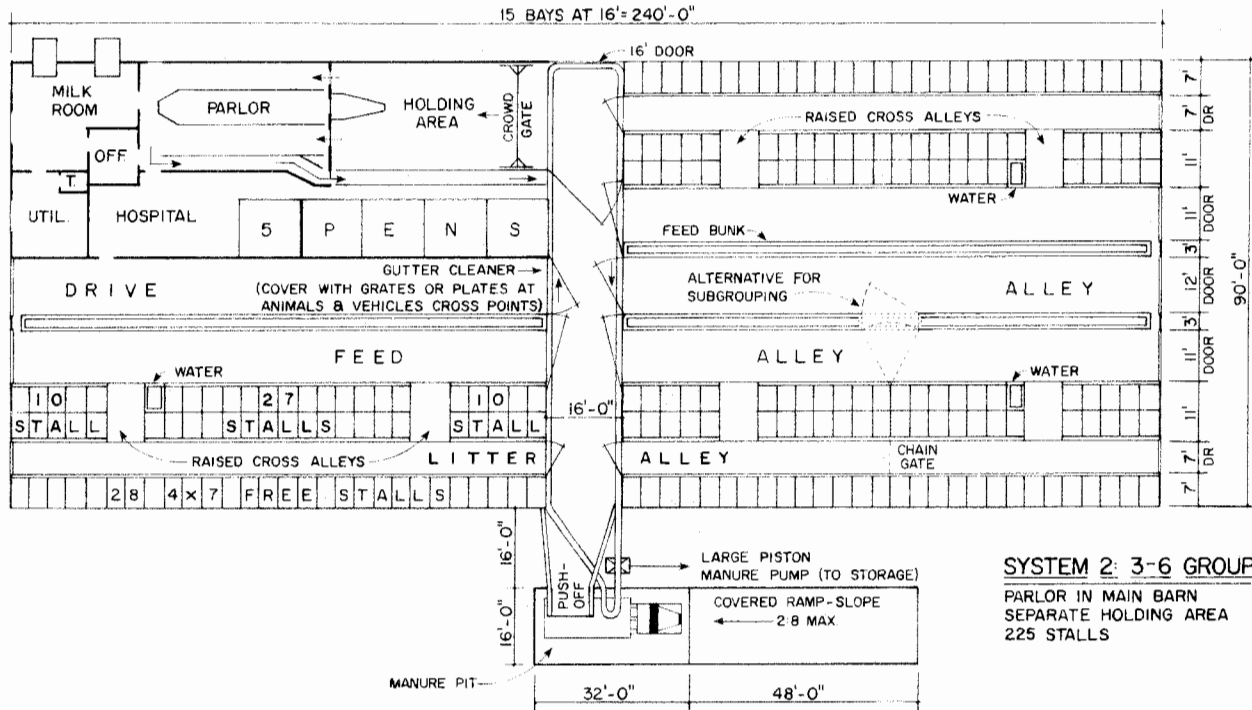

**SYSTEM 2: 3-6 GROUPS**  
 PARLOR IN MAIN BARN  
 SEPARATE HOLDING AREA  
 225 STALLS

0 10' 20' 30'  
 SCALE -- 1" = 20'-0"

**LSU**  
**AgCenter**  
 Research & Extension

**6-ROW HIGH DENSITY  
 FREE STALL DAIRY HOUSING**

MASS '82 EX. 6339 SHEET 1 OF 4

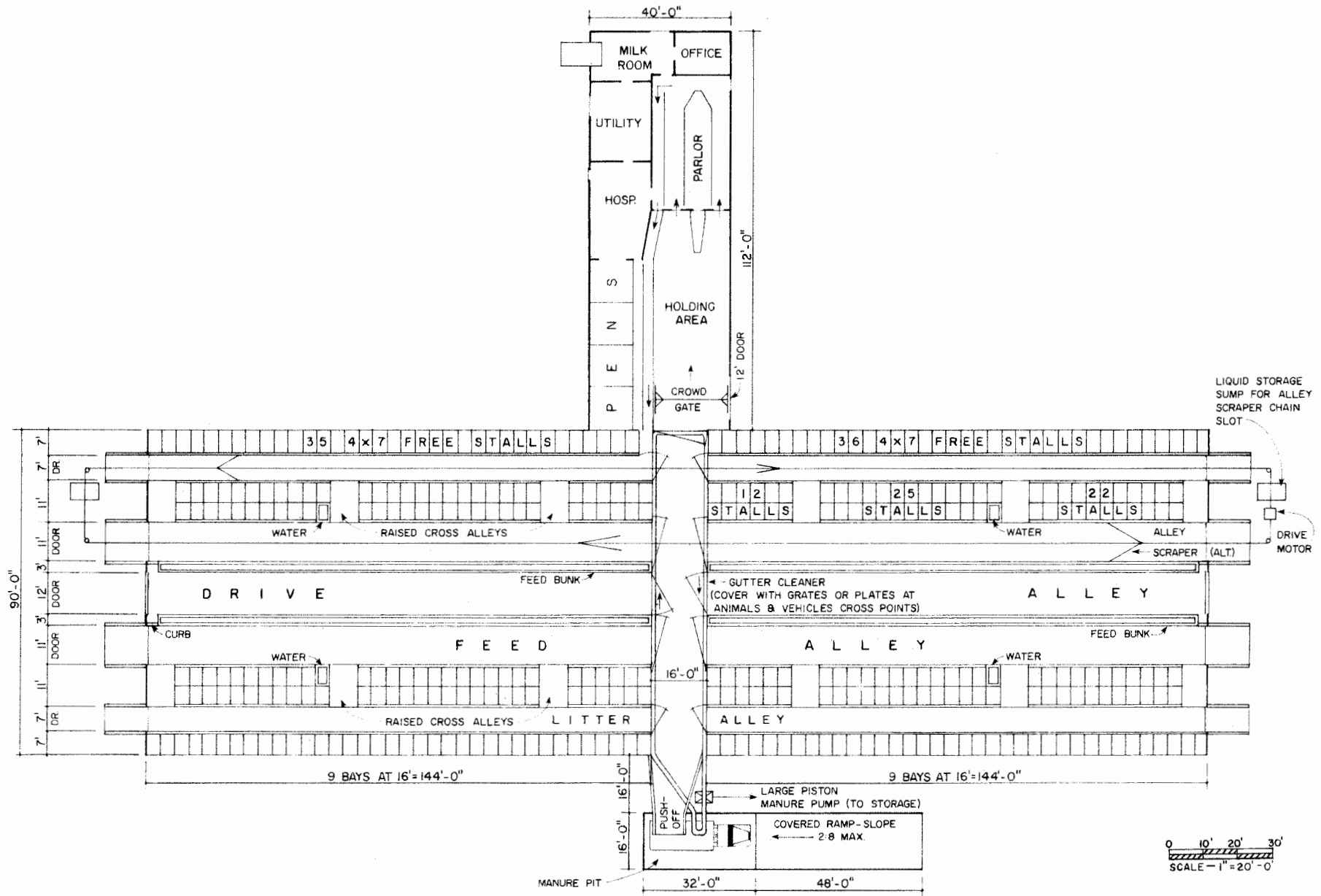

**SYSTEM 3: 4-8 GROUPS**  
 SEPARATE PARLOR AND HOLDING  
 AREA  
 379 STALLS

<b>6-ROW HIGH DENSITY          FREE STALL DAIRY HOUSING</b>		
MASS '82	EX. 6339	SHEET 2 OF 4

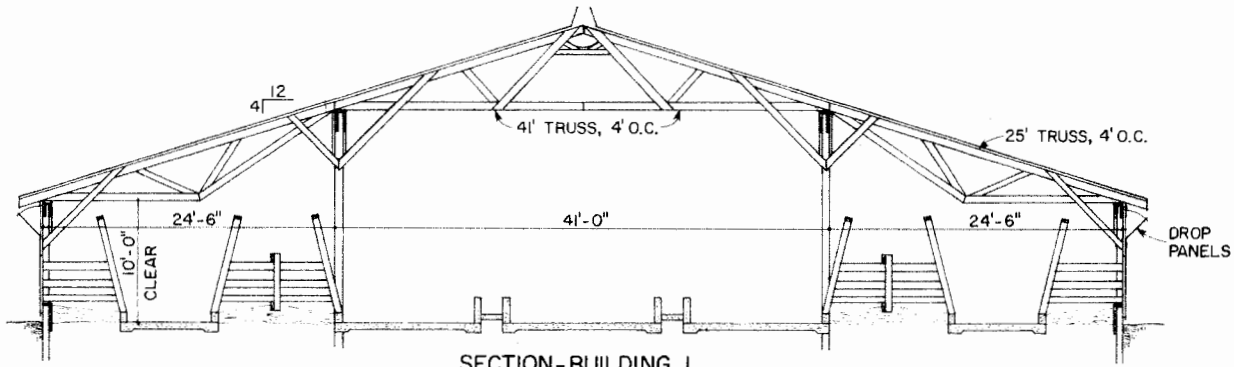

**SECTION-BUILDING 1**  
41' CENTER TRUSS

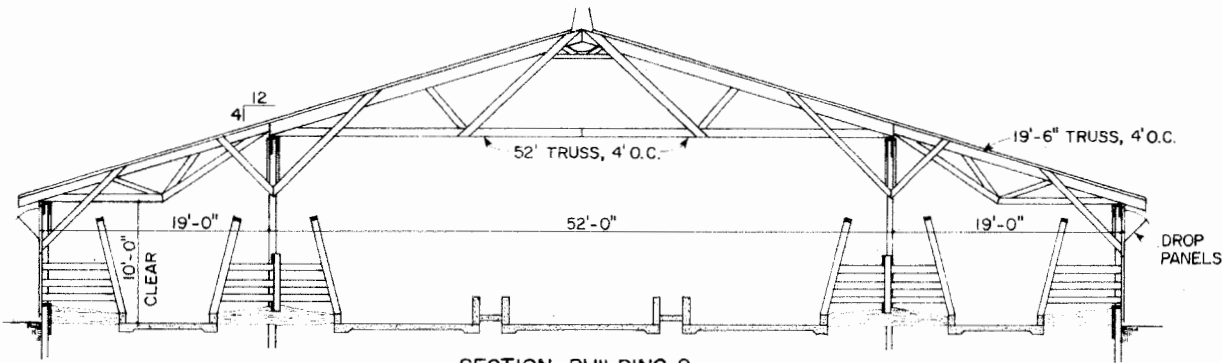

**SECTION-BUILDING 2**  
52' CENTER TRUSS

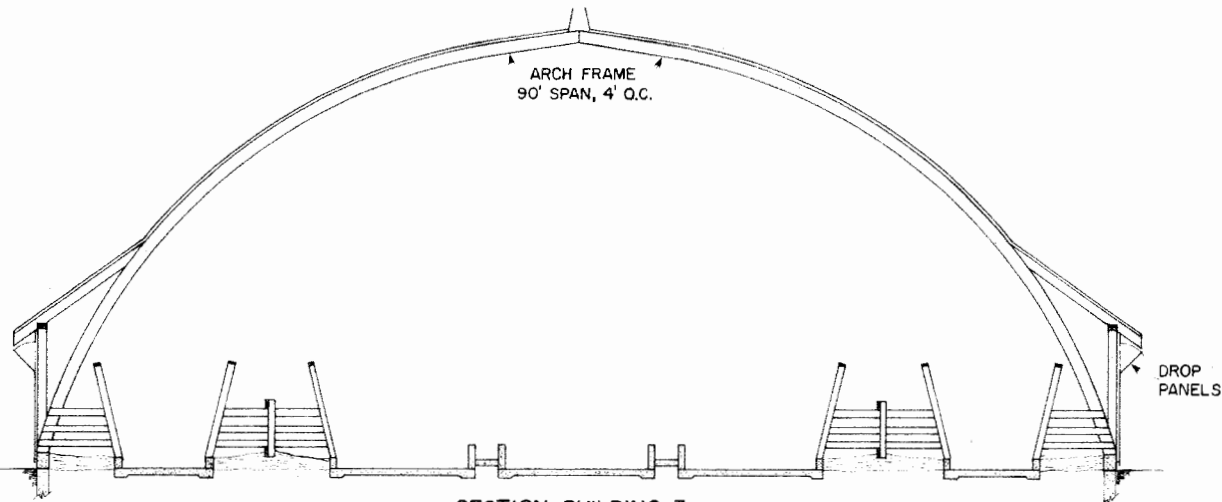

**SECTION-BUILDING 3**  
ARCH ROOF

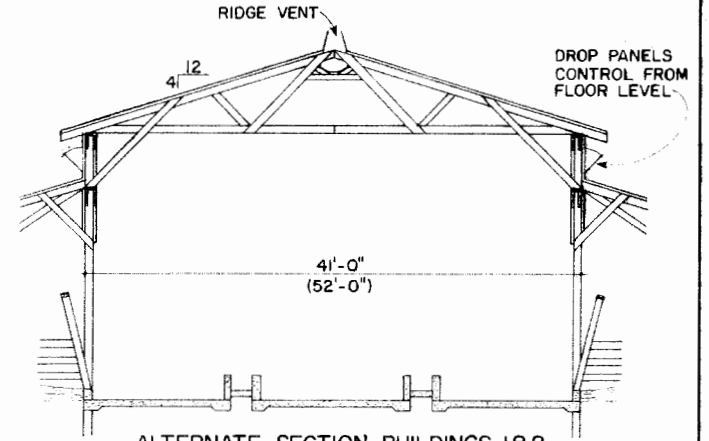

**ALTERNATE SECTION-BUILDINGS 1&2**  
RAISED CENTER TRUSS FOR IMPROVED  
LIGHTING AND VENTILATION

**NOTE**

ROOF FRAMING IS ONLY SHOWN TO PROVIDE CONCEPTS OF SOME ALTERNATIVE ROOF SYSTEMS. TRUSSES WILL NEED TO BE DESIGNED TO MEET LOCAL SNOW AND WIND LOAD CONDITIONS. ROOF LUMBER SIZES SHOULD NOT BE SCALED FROM DRAWING.

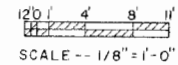

**6-ROW HIGH DENSITY  
FREE STALL DAIRY HOUSING**  
MASS'82 EX. 6339 SHEET 3 OF 4

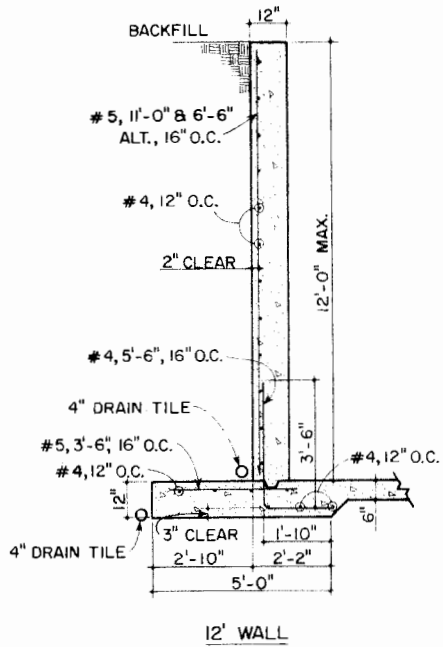

12' WALL

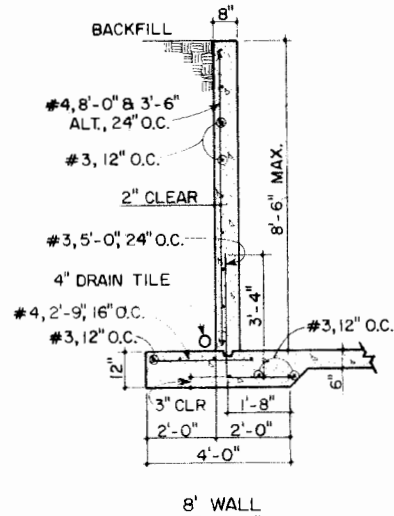

8' WALL

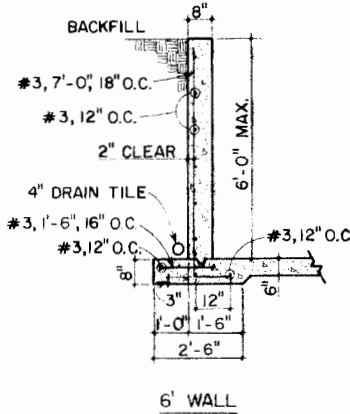

6' WALL

**RETAINING WALL CROSS-SECTIONS**

SCALE: 3/8"=1'-0" FOR BELOW-GRADE MANURE PIT

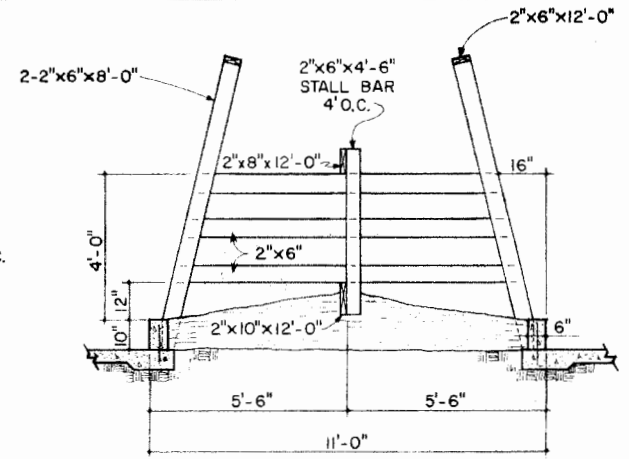
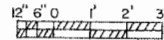

**DOUBLE STALL DETAIL**

SCALE: 3/8"=1'-0"

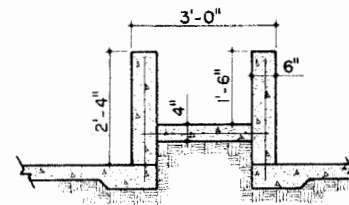
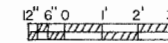

**FEED BUNK DETAIL**

SCALE: 1/2"=1'-0"

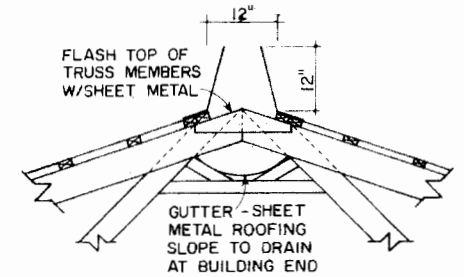
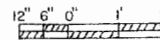

**RIDGE VENTILATOR**

SCALE: 3/8"=1'-0"

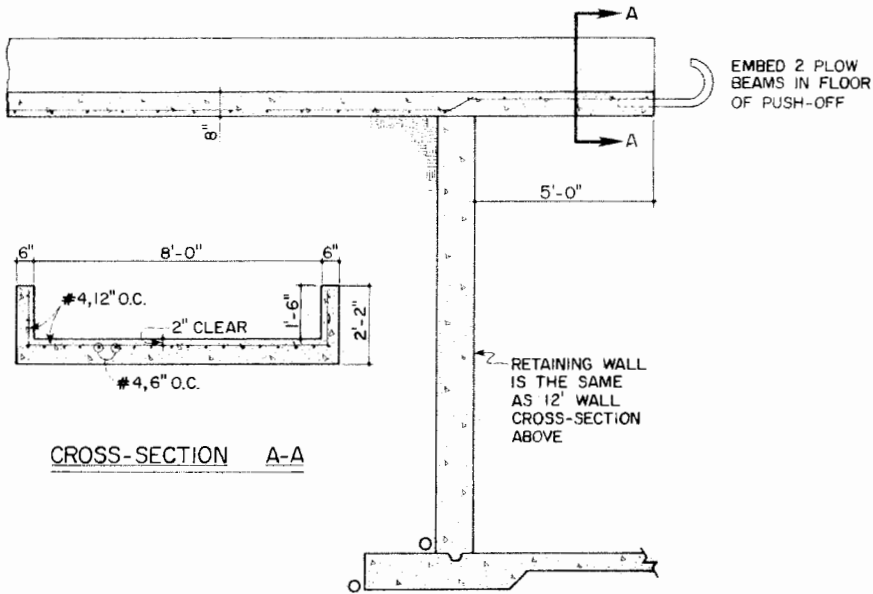
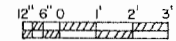

CROSS-SECTION A-A

**MANURE LIP DETAIL**

SCALE: 3/8"=1'-0"

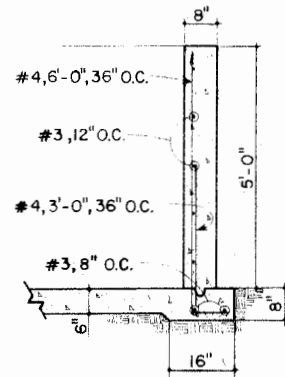
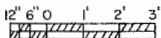

**BUCK WALL DETAIL**

FOR TEMPORARY ABOVE-GRADE MANURE STORAGE AND LOADING

SCALE: 1/2"=1'-0"

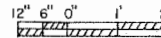

6-ROW HIGH DENSITY FREE STALL DAIRY HOUSING

MASS '82 EX.6339 SHEET 4 OF 4

## Disclaimer

This site makes available conceptual plans that can be helpful in developing building layouts and selecting equipment for various agricultural applications. These plans do not necessarily represent the most current technology or construction codes. They are not construction plans and do not replace the need for competent design assistance in developing safe, legal and well-functioning agricultural building system. The LSU Agriculture Center, the Mid-West Plan Service, the United States Department of Agriculture and none of the cooperating land-grant universities warranty these plans.