

CROSS SECTION OF SILO

NOTES

1. CAPACITY IS BASED ON 40 POUNDS PER CUBIC FOOT.
2. A DAILY USE RATE OF 4" OF SILAGE IS RECOMMENDED IN WARM WEATHER TO KEEP SILAGE FRESH.
3. ALL CONCRETE SHOULD CONTAIN 40% SAND, 60% GRAVEL AND NOT MORE THAN 6 GALLONS OF WATER PER SACK OF CEMENT.
4. ALL WOOD SHOULD BE PRESSURE TREATED WITH 8 POUND RETENTION PER CUBIC FOOT OF WOOD.
5. STAGGER JOINTS IN THE CENTER AND END MATCHED SIDING.
6. BE SURE TO SET GRADE SO WATER WILL DRAIN AWAY FROM SILO.
7. USE RUST PROOF 16d NAILS FOR THE SIDING.

CAUTION:

SOME PRESSURE TREATED POSTS & LUMBER USE PRESERVATIVES THAT EPA DOES NOT ALLOW IN CONTACT WITH FEED. IN SUCH CASES, PLYWOOD OR PLASTIC SHOULD BE USED AS A LINER. CHECK SUPPLIER OR LABELS FOR GUIDANCE.

**BUNKER SILO CAPACITIES
TONS/FOOT OF LENGTH**

| DEPTH | WIDTH | | | | | |
|-------|-------|------|------|------|------|------|
| | 30' | 40' | 50' | 60' | 70' | 80' |
| 8' | 5 | 6.5 | 8.1 | 10.0 | 11.3 | 13.0 |
| 10' | 6.2 | 8.4 | 10.2 | 12.2 | 14.2 | 16.2 |
| 12' | 7.5 | 10.0 | 12.3 | 14.6 | 17.0 | 20.0 |
| 14' | 8.7 | 11.5 | 14.3 | 17.0 | 20.0 | 22.7 |
| 16' | 10.0 | 13.1 | 16.3 | 20.0 | 22.7 | 26.0 |
| 18' | 11.1 | 14.7 | 18.3 | 22.0 | 27.6 | 29.1 |

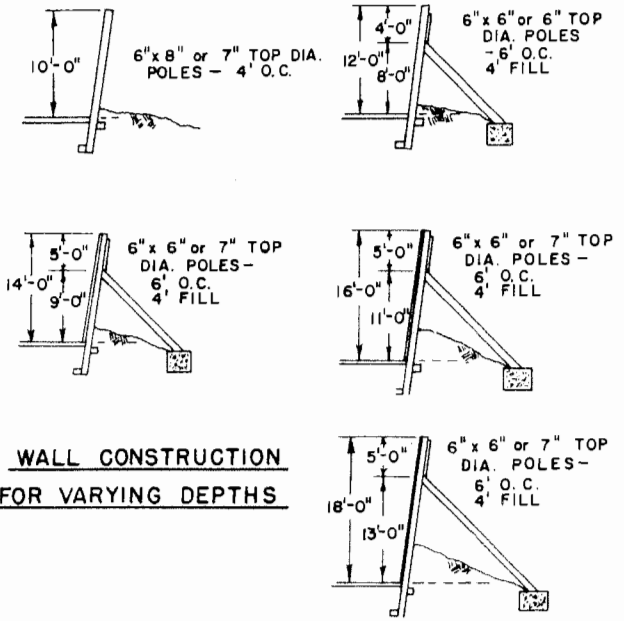

**WALL CONSTRUCTION
FOR VARYING DEPTHS**

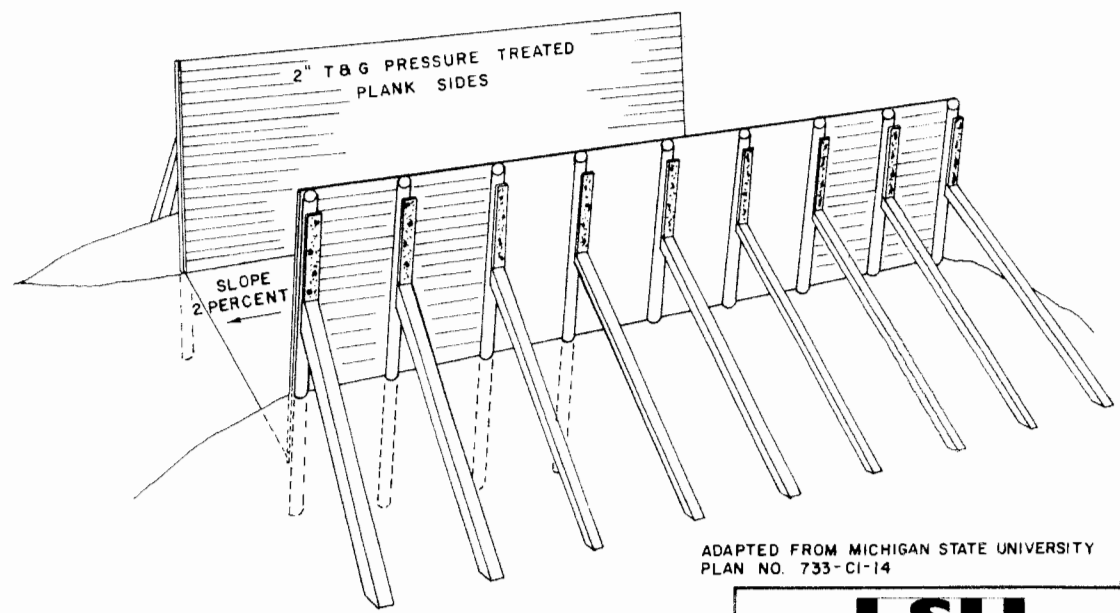

PERSPECTIVE

ADAPTED FROM MICHIGAN STATE UNIVERSITY
PLAN NO. 733-CI-14

LSU
AgCenter
Research & Extension

WOOD BUNKER SILO

| | | |
|--------------|------|--------------|
| MICH.-PA '71 | 6109 | SHEET 1 OF 1 |
| REVISED '88 | | |

Disclaimer

This site makes available conceptual plans that can be helpful in developing building layouts and selecting equipment for various agricultural applications. These plans do not necessarily represent the most current technology or construction codes. They are not construction plans and do not replace the need for competent design assistance in developing safe, legal and well-functioning agricultural building system. The LSU Agriculture Center, the Mid-West Plan Service, the United States Department of Agriculture and none of the cooperating land-grant universities warranty these plans.