

**SUPPORT STRUCTURE (MILKING SIDE) AS VIEWED FROM MILKING SIDE**

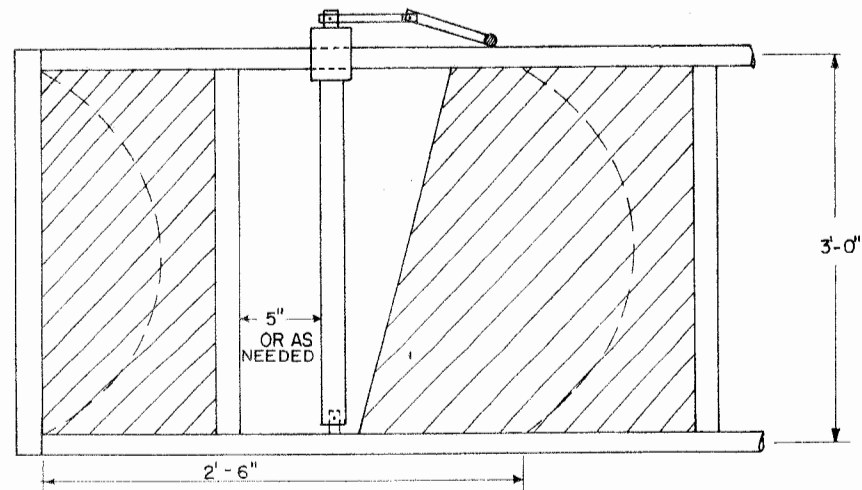

**CLOSED**

**LOCKING STANCHION DETAIL (NO SCALE)**

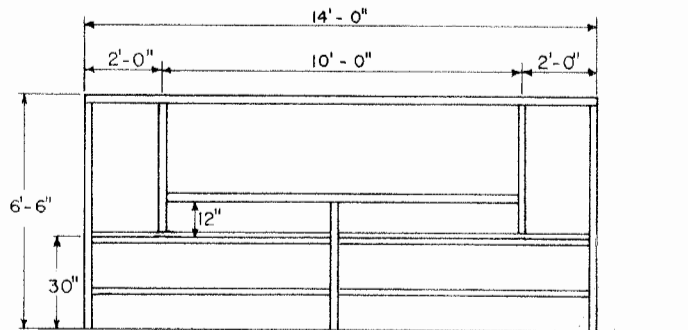

**SUPPORT STRUCTURE (STANCHION SIDE) AS VIEWED FROM MILKING SIDE**

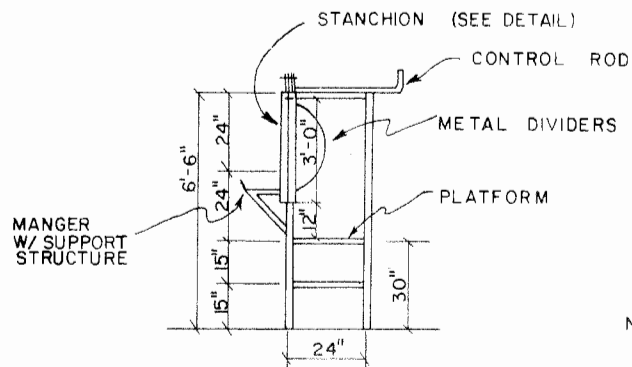
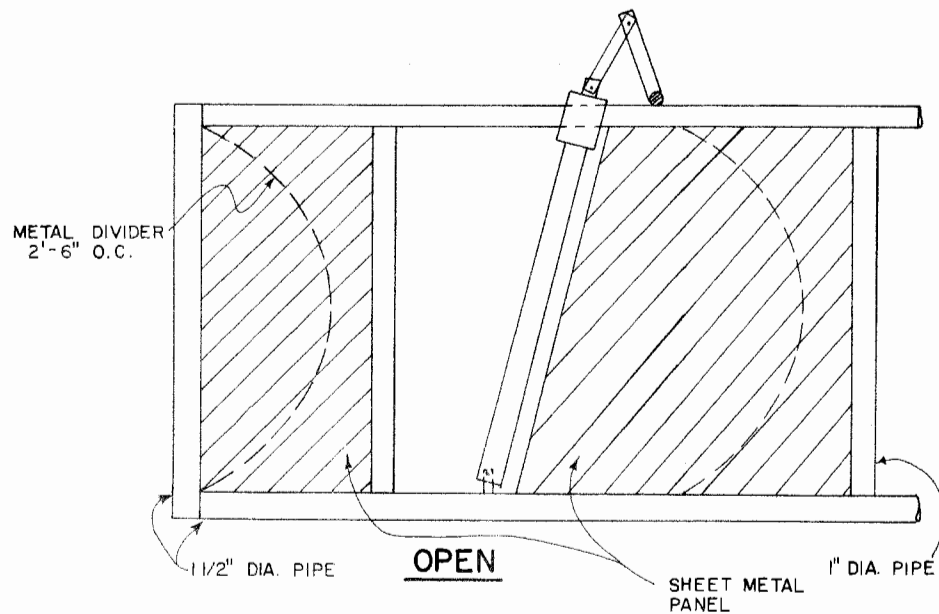

**SIDE VIEW OF STANCHION**

NOTE: PLATFORM HEIGHT DIMENSION CAN BE CHANGED TO SUIT OPERATOR BUT 30" IS ABOUT MAXIMUM IF CONTROL ROD IS TO REMAIN WITHIN REACH.



4 GOAT HERRINGBONE DAIRY PARLOR AND CHEESE PLANT

GA '88 6405 SHEET 2 OF 2