

## Effective Design Concepts



**Dr. Ron Sheffield**  
LSU Ag Center, Biological & Agricultural Engineering  
rsheffield@agcenter.lsu.edu



## Effective Design Concepts

- Site planning
- Zoning
- Sprinkler layout
- Attention to details





## Site visits

- Denote all plantings
  - Shrubs
  - Planting beds
  - Trees
- Retaining walls
- Abrupt grade changes,
- Sunlight exposure variations
- Soil types





## Site visits

- Location of water main
- Location and size of water meter and service
- Static water pressure @ hydrant
- Elevation differences (high and low)
- Soil type and general conditions
- Suitable locations for automatic controllers
- If pumping, info on electric service (1 or 3 phase), site conditions of pump location







## Maps

- Purchase plats
- Surveys
- Aerial photos



## Check the Pressure

- City mains are seldom at rest, but are referred to as the *static pressure*
- Pressure in main will vary due to:
  - Time of day, month, day of week
  - Number of houses in new subdivision
  - Gauge
- Check pressure at different flow rates



## Zoning Concepts







## Zoning an Irrigation System

Factors to consider....

- Plant requirements
- Water supply
  - Capacity
  - Flow velocity
  - Pressure
  - Operating Time
- Size of mainline
- Zone separation for system control

## System Design



- Remember.. plants, trees and turf have different water needs and ET rates
- Runoff and ponding don't leave a "professional appearance"







## Pressure Variations

When low static pressure is:	Allow:	Design for:
50 psi	10%	45 psi
75 psi	15%	65 psi
100 psi	20%	80 psi
125 psi	25%	95 psi

## Zone Piping Layout

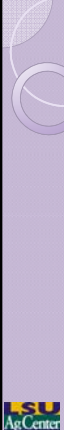

- Location of water supply
- Type and location of backflow prevention equipment
- Desired location of zone control valves
- Type of pipe
- Type of installation equipment
  - Trencher
  - Pipe-puller

## Looping Mains

When possible, looping an irrigation main has several advantages:

- Reduced pressure loss with same piping
- Reduced pipe size and cost with same pressure loss
- Reduced pipe size and cost with reduced pressure loss



- ### Considerations for sprinkler spacing
- Selection of sprinklers, valves and controllers
  - Uniformity of distribution
  - Spray beyond borders of coverage requirement
  - Separate layouts for areas with different water requirements
  - Variations in water pressure

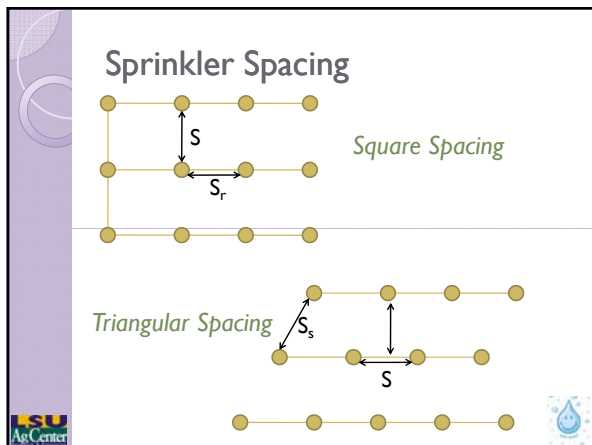

- ### Head Spacing
- Uniformity
  - Wind effects
  - Dependability of sprinklers
    - A broken or stuck sprinkler isn't doing its job
  - Sprinkler overthrow and overlap
    - Runoff on streets or sidewalks many times is the result of improper sprinkler layout or excessive applications due to overlap

- ### Head Spacing
- Size and shape of landscape area
  - Size, type and spacing of planting material and any obstructions to spray coverage
  - Influence of budget on product selection and design criteria
  - Site conditions
    - Capacity of water supply
    - Available and variations in pressure
  - Designers knowledge and experience



- ### Compensating for Wind
- 0 – 3 mph winds
    - $S_s$  &  $S_r$  = Diam. \* 0.55
  - 4 – 7 mph winds
    - $S_s$  &  $S_r$  = Diam. \* 0.50
  - 8+ mph winds
    - $S_s$  &  $S_r$  = Diam. \* 0.45
- 
- The diagram shows two versions of the spacing diagrams from the previous slide. The top version shows square spacing with a horizontal arrow labeled  $S_r$  and a vertical arrow labeled  $S$ . The bottom version shows triangular spacing with a diagonal arrow labeled  $S_s$  and a vertical arrow labeled  $S$ .

### Gross Precipitation Rate

*Theoretical precipitation rate; does not account for losses from sprinkler to soil*

$$PR = \frac{Q}{A}$$



PR = Gross Precipitation Rate  
Q = Flow; A = Area

$$PR_{in/hr} = \frac{96.3 \times Q_{gpm}}{A_{ft^2}}$$

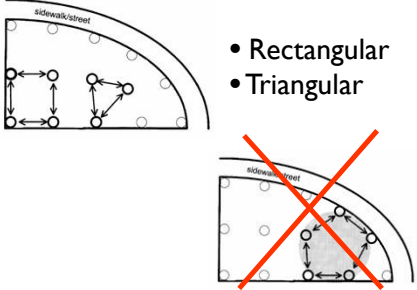

### Sprinkler Spacing





- Rectangular
- Triangular

### Line out Edge

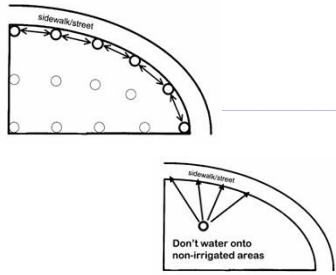



Don't water onto non-irrigated areas

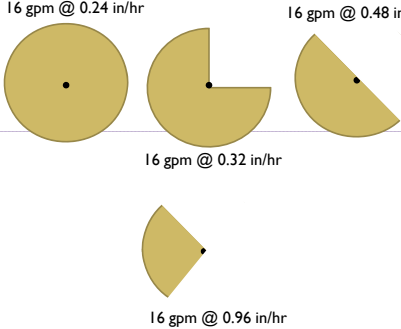

### Changing sprinkler arcs



- 16 gpm @ 0.24 in/hr
- 16 gpm @ 0.48 in/hr
- 16 gpm @ 0.32 in/hr
- 16 gpm @ 0.96 in/hr



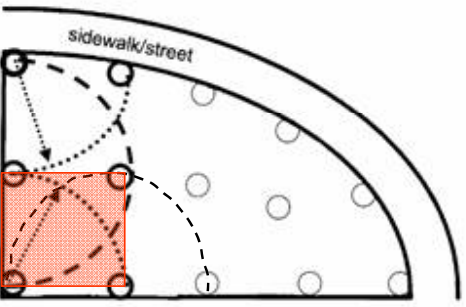

### Matched Precipitation Rate (MPR)

### Matched Precipitation Rate (MPR)

- Matched precipitation heads have flow rates that are proportional to the degree of arc
  - 8 gpm @ 360°
  - 4 gpm @ 180°
  - 2 gpm @ 90°
  - 1 gpm @ 45°

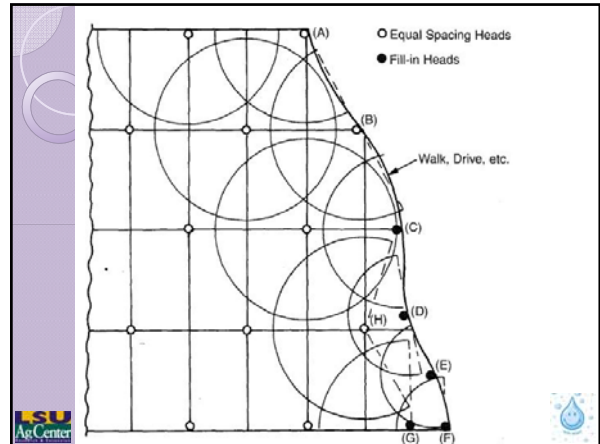
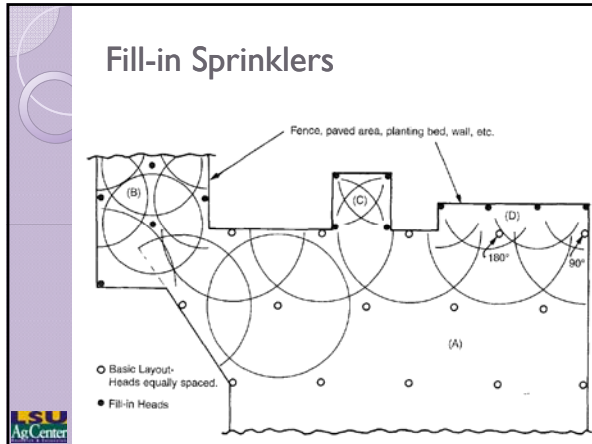

### Symmetrical layouts

- Most uniform application possible
- Plan has a “professional appearance”
- The installed system will reflect a “professional appearance” in operation

### Attention to details

### Sprinkler Adjustments

lawn area sidewalk

sprinkler delivery area

Arc angle

Sprinkler angle

Adjust head height

### Inspect after 1<sup>st</sup> operation

Cracked Pop-Up Head

Clogged Nozzle



### Watch for runoff



### Check delivery pressure



### Check zones with rain gauges



### Do it right the first time... repairs are a pain .....



### Effective Design Concepts



**Dr. Ron Sheffield**  
LSU Ag Center, Biological & Agricultural Engineering  
rsheffield@agcenter.lsu.edu

