

GRAIN DEPTH AT WALL = 7'11" FOR SHELLED CORN WHEN PILED AT ITS ANGLE OF REPOSE, 19°, TO A 14' CENTER HEIGHT IN A 60' WIDE BUILDING. STORES 640/bu/ft OF BUILDING LENGTH.

NOTES

- ① USE TRUSS RAFTERS SIZED FOR 48" SPACING TO SUIT LOCAL ROOF SNOW AND DEAD LOAD AND SPAN OF BUILDING. IF LOADS REQUIRE SPACING LESS THAN 48", ADJUST STUD SPACING SO THAT KNEE BRACING ALIGNS WITH TRUSS RAFTER AND STUDS. GRAIN PRESSURE AGAINST WALLS REQUIRES EXTRA TIE STRENGTH AT TOP OF PLATE. SEE (8) ON SHEET #2 AND (12) ON SHEET 3.
- ② LENGTH VARIABLE IN MULTIPLES OF 8'-0".
- ③ STUD WALL HEIGHT MAY BE 10', 12', OR 14'.
- ④ SLIDING DOORS
- ⑤ MAN DOOR, 2'-8" x 6'-8"
- ⑥ CONTRACTION JOINT IN CONCRETE FOUNDATION NOT OVER 50' O.C.
- ⑦ TRUSS RAFTER CROSS-BRACING, SEE SHEET #2, NOTE (20).
- ⑧ L-ANCHORS, SEE SHEET #3, NOTE (*), (**).
- ⑨ SIDING AND ROOFING CAN BE OWNER'S CHOICE. DETAILS SHOWN FOR METAL ROOFING AND METAL SIDING.
- ⑩ CONCRETE APRON 5" THICK MINIMUM, WIDTH AND LENGTH TO SUFFICIENTLY ACCOMMODATE TRUCK OR OTHER LARGE EQUIPMENT
- ⑪ RIDGE VENTILATION. CAPACITY TO SUIT THE INTENDED USE.
- ⑫ LIGHTNING PROTECTION SYSTEM.

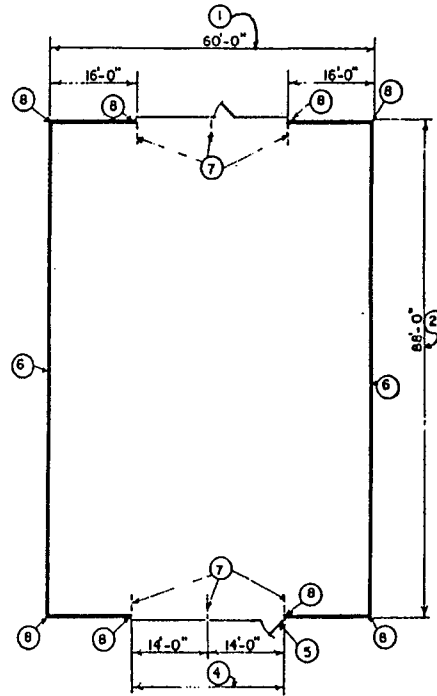
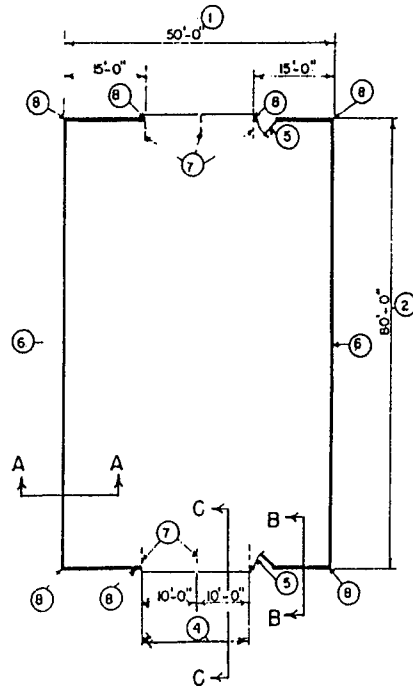
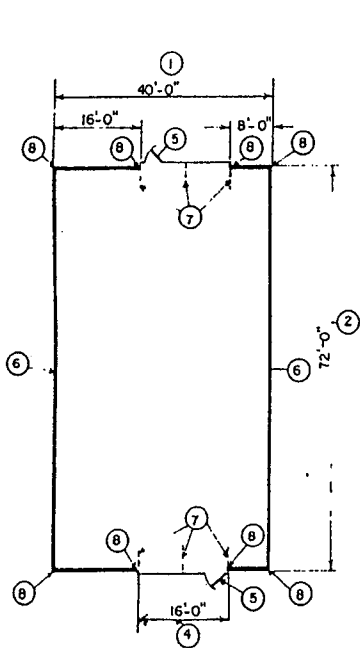

SPECIFICATIONS

UNLESS OTHERWISE SPECIFIED, ALL CAST-IN-PLACE CONCRETE IS TO BE MINIMUM OF 4000 PSI AT 28 DAYS, 6% AIR-ENTRAIMENT.

ALL REINFORCING STEEL TO BE MINIMUM OF 60,000 PSI DEFORMED BARS; PROVIDE 2" CONCRETE COVER OVER REINFORCING STEEL.

ALL EXPOSED STEEL TO BE GALVANIZED OR PAINTED TO RESIST CORROSION FROM MOISTURE.

ALL FRAMING LUMBER, INCLUDING STUDS, IS NO.2 (OR BETTER), S-P-F SPECIES GROUP, UNLESS OTHERWISE SPECIFIED.

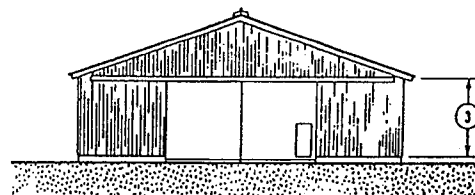
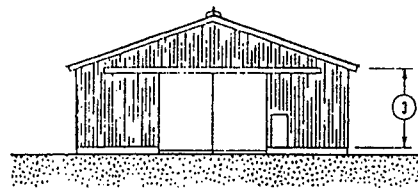
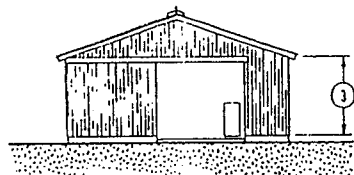

MACHINERY OR GRAIN STORAGE
KNEE BRACED CONSTRUCTION

MD '87 6394 SHEET 1 OF 3

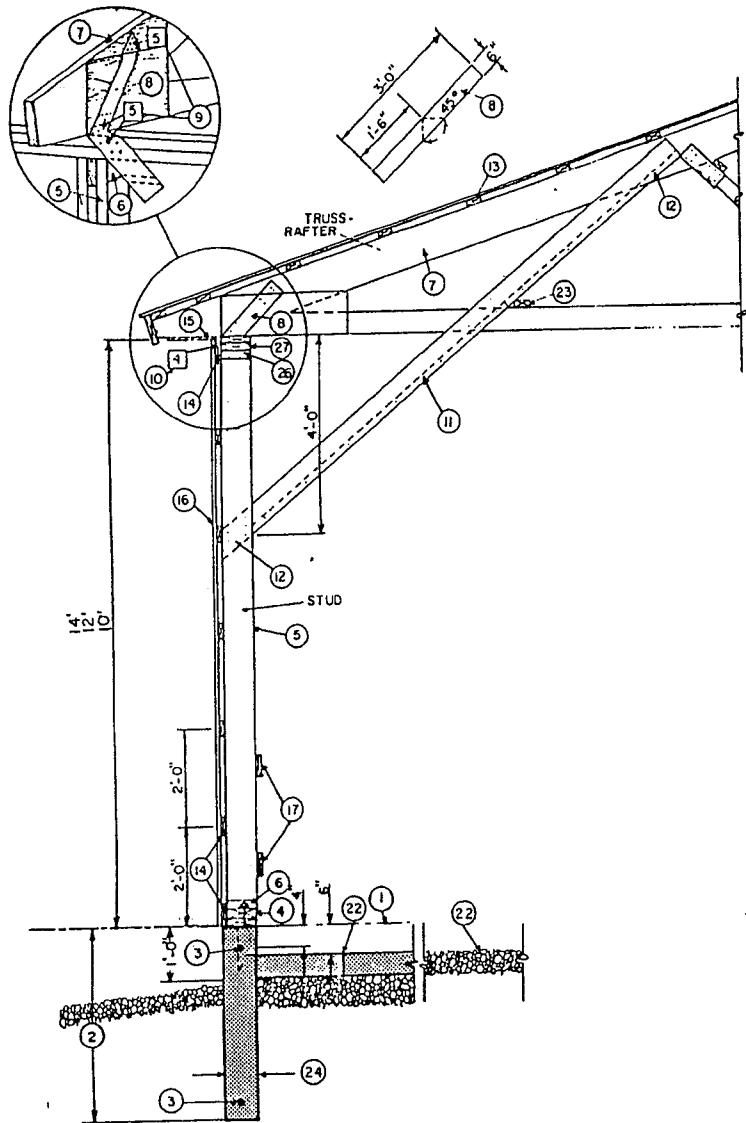

SECTION A-A
TYPICAL SIDEWALL
SECTION

TABLE 1'- KNEE BRACING

WALL HEIGHT	MAX. KNEE BRACE SPACING	NO. OF 4" SPIRAL NAILS AT EACH JOINT
10'	8' o.c.	4
12'	6' o.c.	4
14'	4' o.c.	4

DESIGNED FOR 80 MPH WIND SPEEDS.

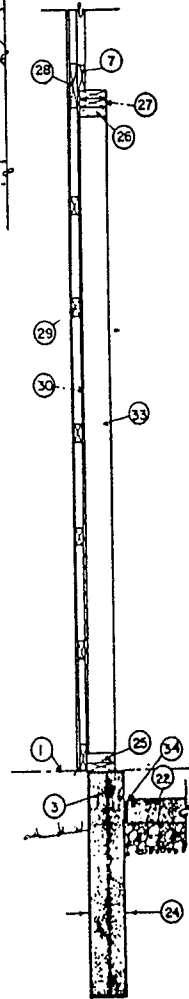

SECTION B-B
ENDWALL DETAIL

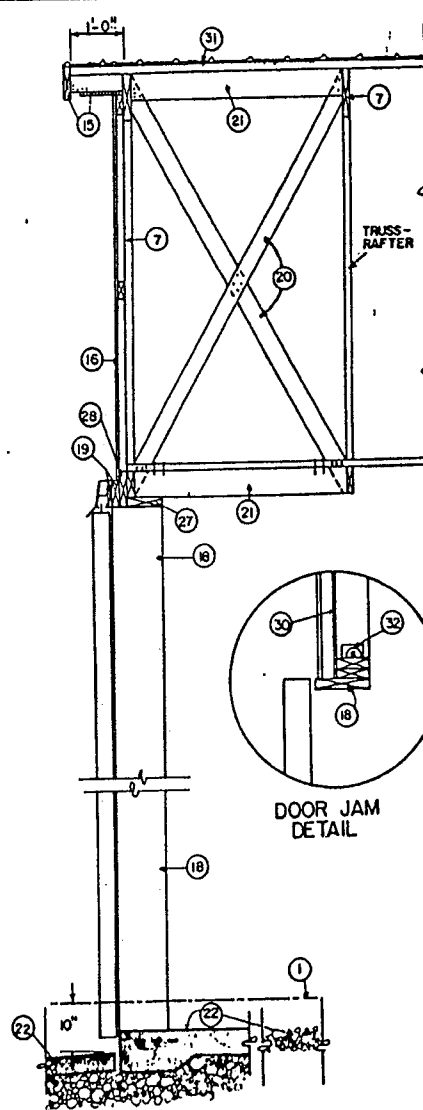

SECTION C-C
CROSS BRACING FOR
FIRST TWO TRUSSES
AT EACH END AND
DOORWAY DETAIL

1. Datum line, top of concrete foundation.
2. Concrete foundation 8" wide to compact soil and frost line - minimum depth 3'. Soil bearing less than 2T/ft² will require a wider footing.
3. Rebars, #6 continuous except at expansion.
4. 2x6" continuous sill, 5/8" x 12" anchor bolts @4'0" o.c. Nuts and 3" square washers without grain pressure. See Table 2 for grain storage plate and anchorage requirements.
5. 2x6 studs, 2'-0" o.c. double at each knee brace using 1 1/2" spacer blocks top and bottom; see Table 1 for knee brace spacing.
6. 20 ga. galv. steel anchors site bend from stock cut 6" wide, nailed with 6d threaded nails both sides of knee braced studs.
7. Truss rafters @ 4'0" o.c. (or closer if truss design requires) centered over studs.
8. 20 ga. galv. steel strap ties, each truss rafter to wall framing, site bend on dotted lines, hammer bend to underside of top wall girt; make 'rights' and 'lefts' for 2 sides of building. Nail with 6d threaded nails.
9. 2 1/2" special concrete nails; number indicated in box (i.e. [5] = 5 nails).
10. 4" threaded nails thru 1x4x8; number as indicated (i.e. [4] = 4 nails).
11. 2x6 knee brace @ 8'0" o.c. between 2 studs and lapping truss rafter; 2x4 stiffener nailed w/8d nail 2' o.c. on edge behind, notched at stud and truss chords.
12. Knee brace nailing, see Table 1.
13. 2x4 roof purlins @ 2'0" o.c., joints staggered 8'0" at truss rafters; steel roofing.
14. With studs @ 4'0" o.c., use 2x4 girts spaced 2' apart or with studs @ 2'0" o.c. nail siding to studs or use 1x4 (full dimension) girts; top & bottom girts 5 1/2" wide.
15. 3/4" soffit board, 2" wide continuous vent slot w/screen 1 1/2" face board, 1 1/2" blocking @ 4'0" o.c. supports soffit.
16. Vertical steel siding, self-drilling roofing screws to [14].
17. 2x6 bumper guards, continuous all around spaced midway between [14] when used for machinery storage.
18. Side jamb at least 2 1/2" wider than studs.
19. 1x6, with 2x6 block, track boards.
20. 2x4 cross-bracing at center and ends of endwall door spans.
21. 1 1/2" blocking between end truss rafters at [20].
22. Optional, 5" floating concrete slab floor on packed granular fill, or crushed stone floor.
23. 2x6 laid longitudinally at quarter points across lower chord, nail at each truss.
24. 8" min. wide concrete foundation.
25. 3/4" hooked anchor bolt, 4'0" long at endwall corners and side jambs.
26. Joist hanger at each stud to plate connection.
27. Double top plate, single at doorway.
28. 1 1/2" shear-plank and track board (1 1/2" deep over door, 9 1/4" deep beyond door); 4" spiral nails to [7] and [27].
29. Top and bottom girts 2x6, others 2x4 @ 2'0" o.c.
30. 4" ext. plywood or oriented strand board applied to outside of studs before [28].
31. Roofing.
32. L-anchor from 4"x4"x1'6" steel strap @ end-walls, corners and door jambs, 3 1/4"x4" machine bolts; 3" square washers.
33. 2x6 studs @ 4'0" o.c. NOTE: If grain is to be piled against end walls, design the same as side walls.
34. Expansion board between floor and wall.



MACHINERY OR GRAIN STORAGE
KNEE BRACED CONSTRUCTION

MD. '87 6394 SHEET 2 OF 3

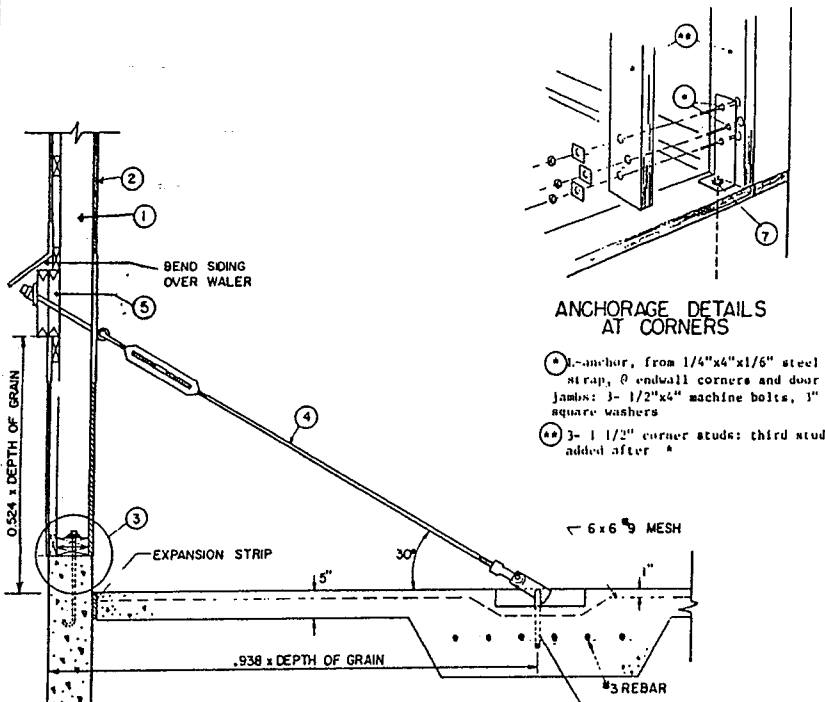

SIDE WALL TIE ROD DETAIL

TABLE 2 - SIDE WALL CONSTRUCTION

Details for shelled corn piled to filling angle (angle of repose)
 Wheat depths should be about 10% less, and soybeans could be 10% deeper.
CAUTION: End walls will need cable anchorage if loaded above 3 feet in depth.

SIZES AND SPACING

GRAIN DEPTH AT WALL	STUDS	ANCHOR BOLTS
4 ft. or less	2x6, 2' o.c. + extra 2x6 at each knee brace per perspective drawing	5/8" bolts 32" o.c. w/single plate, 64" o.c. w/double plate
6 ft.	2x6, 2' o.c. + extra 2x6 at each knee brace per perspective drawing	5/8" bolts 24" o.c. w/double plate
7 ft.	2 - 2x6 2 ft. o.c.	3/4" bolts 24" o.c. w/double plate
8 to 12 ft.	2 - 2x6 2 ft. o.c. plus tie rods (see detail)	1" bolts 21" o.c. w/double plate

NOTE: Each stud to be anchored to 2x6 sill plates with framing anchor. Framing anchors, 20 gauge, 6" wide (min) to resist outward horizontal thrusts as follows: @4' depth, a total of 300 lbs. for every 2 ft. o.c. @ 6' depth, 700 lbs for every 2 ft. o.c.; @ 7' depth, 900 lbs. for every 2 ft. o.c.; @12' depth (with tie rods) 1200 lbs for every 2 ft. o.c. Standard stud anchor usually is rated at 400 lbs. Be sure to adequately nail.

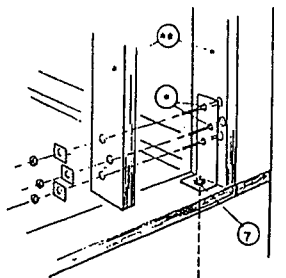

ANCHORAGE DETAILS AT CORNERS

- ① - anchor, from 1/4"x4"x1/6" steel strap, @ endwall corners and door jams; 3- 1/2"x4" machine bolts, 1" square washers
- ② - 1 1/2" corner studs; third stud added after *

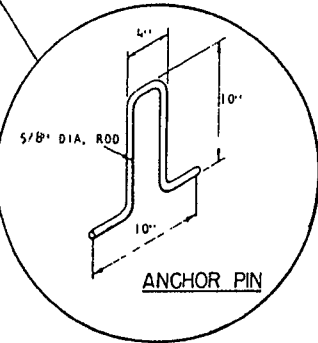

ANCHOR PIN

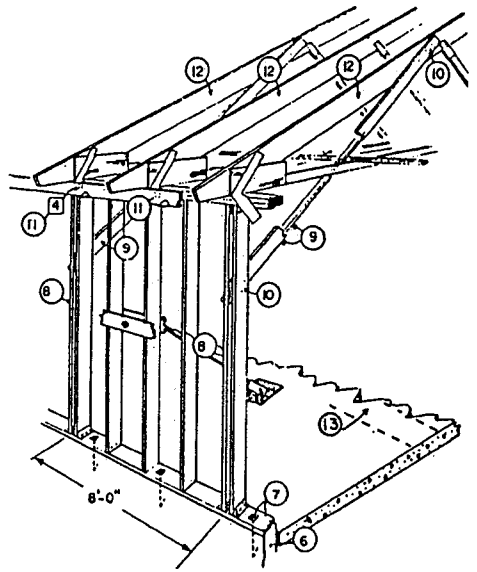

PERSPECTIVE

See TABLE 2 regarding stud size and spacing for grain

1. See Table 2 for stud size and spacing relative to wall pressures when grain is banked upward from the wall at its angle of repose. Grain storage design based on shelled corn using an equivalent fluid density of 22.5 lbs/cu. ft. when not leveled. Stud design considered adequate to support grain side thrust as well as heavily snow laden roof (total roof loads of 50 psf with a 60 foot span).
2. See Table 3 for plywood thickness relative to grain depth.
3. See Table 2 for plate anchorage specifications relative to grain depth.
4. Use cable, flat iron, or rod ties for grain depths greater than 7 ft. Space ties 6' o.c. along waler. Turnbuckles or threaded rods will be needed to tighten ties after connecting between hooks in floor and wall. Cable, turnbuckles, clamps and rods to withstand 3.5 tons tension. Use 3/8" wire rope or 1/2" steel rod. **NOTE:** Cable could be anchored to opposite post instead of floor, perhaps a less expensive option but it will be less convenient for unloading.
5. Waler: 2 - 2x10's securely fastened to outside of studs. Use 1/2" (min. diam) x 18" eye bolt with 1/2" thick 4"x4" steel plate and beveled washer to bear against waler.
6. Foundation
7. See Note 4, sheet 2 for sill detail.
8. See Note 5 of sheet 2 for studs at knee brace.
9. See Note 11 sheet 2 for knee brace specifications.
10. Knee brace. See Note 12, sheet 2.
11. Rafter anchorage, see Note 10, sheet 2.
12. Truss rafters to meet local snow & roof load criteria as well as grain load. Outward horizontal thrust at top plate due to grain will be greatest with 7' depth and no cable -- about 90 lbs per running foot of building length at 14' wall height, 160 lb/ft at 12' wall height and 252 lb/ft with 10' wall height.
13. **CAUTION:** Aeration ducts may be needed.

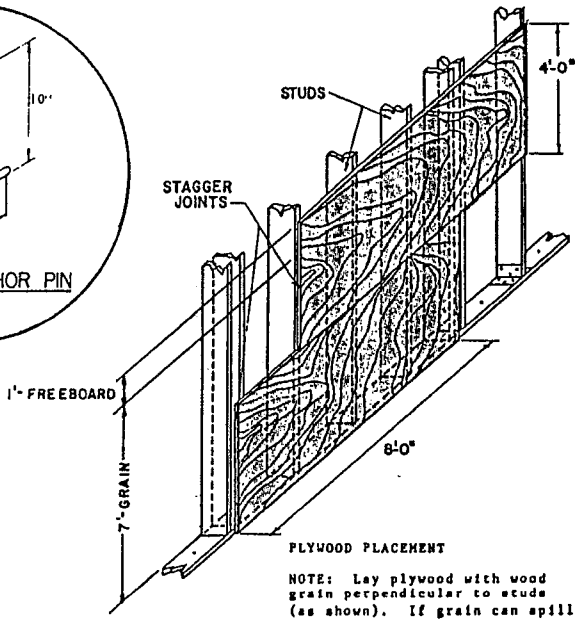

PLYWOOD PLACEMENT

NOTE: Lay plywood with wood grain perpendicular to studs (as shown). If grain can spill over top of plywood allow 1 inch slot above sill plate for clean out.

TABLE 3. Maximum loading depth (feet below surface of level grain) for various thickness of plywood on interior of studs. See illustrations regarding direction of plywood grain.

PLYWOOD THICKNESS OR APA RATING	MAXIMUM GRAIN DEPTHS (22.5" BETWEEN STUDS)
1/4"	3.5 feet
32/16	4.5 feet
5/8"	4.7 feet
3/4"	6.0 feet
42/40	7.0 feet
48/24	9.3 feet
1"	10.8 feet
2-4-1	20.6 feet

Inch size refers to Group 1 sanded plywood - ratio (i.e. 32/16) refers to span rated plywood. Design based on Durum wheat and vertical walls. See Note 6, sheet 3, regarding depth adjustments for other grains. **NOTE:** 1 inch T&G or ship lap boards could be used in lieu of plywood for depths of 10 feet or less.



LSU
AgCenter
RESEARCH & EXTENSION

MACHINERY OR GRAIN STORAGE KNEE BRACED CONSTRUCTION		
MD '87	6394	SHEET 3 OF 3

Disclaimer

This site makes available conceptual plans that can be helpful in developing building layouts and selecting equipment for various agricultural applications. These plans do not necessarily represent the most current technology or construction codes. They are not construction plans and do not replace the need for competent design assistance in developing safe, legal and well-functioning agricultural building system. The LSU Agriculture Center, the Mid-West Plan Service, the United States Department of Agriculture and none of the cooperating land-grant universities warranty these plans.