

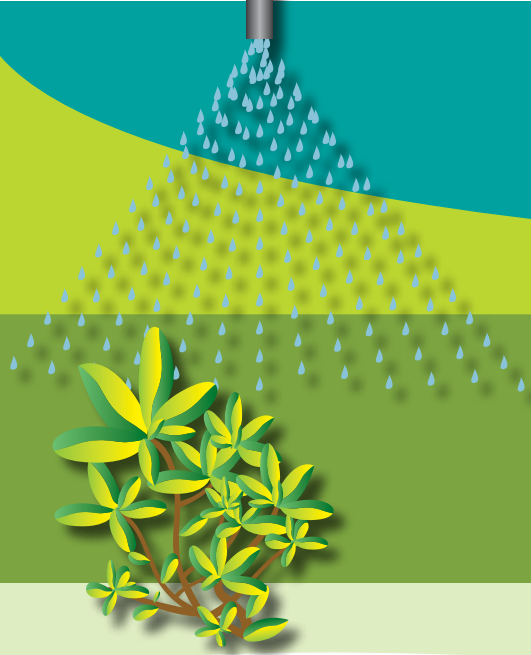

# Agricultural Sprayer Calibration





# Agricultural Sprayer Calibration

**Calibration** is the process of adjusting sprayer components to deliver the desired volume (rate) per area when applying chemical products.

One of the most important objectives during spraying is the delivery of the correct volume per area (gallons per acre). The efficiency of the chemical intimately depends on the application of an accurate rate.

Four important checks need to be done in the sprayer to assure proper calibration:

1. **Speed.** Speed determines operation productivity (acre/hour or acre/day). For sprayers not equipped with electronic flow control, maintaining proper speed is critical to achieve the correct rate distribution (gallons per acre or GPA). Misapplication is directly related to variations in speed. When the sprayer is equipped with an electronic flow control, small variations in speed are compensated by the controller.
2. **Effective Swath Width.** The swath width determines the area treated with each pass of the sprayer. The effective swath width changes whether the application is broadcast, banded or a direct spraying.

3. **Nozzle Flow.** Hydraulic nozzles produce a determined flow per unit of time. This flow is pressure-dependent. It is important to know for a particular type of nozzle and operating pressure, what the flow per unit time is (gallons per minute or GPM).
4. **Operating Pressure.** Pressure affects the volume delivered by the nozzles. Increasing pressure increases nozzle flow, but the relationship is not linear.

## Why do we calibrate sprayers?

- To ensure that the correct volume is being delivered per unit of area.
- To ensure that mixture of water and active ingredient is being done correctly.

How to calibrate a sprayer? Follow these simple steps to assure proper calibration.

## Before You Start

Agricultural sprayers are used daily in the delivery of chemicals to our crops ensuring a productive yield. Misuse of chemicals, however, is a potentially dangerous situation. Some chemicals used in agriculture are highly toxic, and proper safety equipment has to be used during application. During calibration procedures, even though no chemical is being used, safety should still be our primary concern. Never use your mouth to clean clogged nozzles or strainers. Use chemically resistant gloves, protective clothing and goggles when manipulating nozzles, strainers, fittings, etc. Use only water during calibration.

### 1. Speed Check

Make sure you know at what speed you're spraying. With the advent of automatic spray controllers, many people assume that speed is not an issue in calibration anymore and that the computer will compensate for it. That's not always the case. During calibration, it is very important to know the average speed of the sprayer. Follow this simple procedure to find out.

- Measure a distance between 100 to 200 feet in a location that resembles the ground where you often spray.
- Using the same tractor gear arrangements that are used during spraying, record the time in seconds spent to cover the distance marked. For better accuracy, check the speed with the sprayer carrying a half load.
- Repeat this process 3 or 4 times.
- Calculate the speed using the following equation:

$$S = \frac{L}{T} \times 0.6818$$

Where S represents the calculated speed (mph), L stands for the length (feet) and T for time (seconds). 0.6818 is a conversion factor to transform the units from feet per second to miles per hour.

Let's work out an example:

- Length marked: 150 feet.
- Time spent:
  - ◇ **1st Time:** 11.5 seconds
  - ◇ **2nd Time:** 11.1 seconds
  - ◇ **3rd Time:** 11.3 seconds
  - ◇ **4th Time:** 11.2 seconds
  - ◇ **Average Time Spent:**

$$\frac{11.5 + 11.1 + 11.3 + 11.2}{4} = 11.3 \text{ s}$$

- Speed is calculated as

$$S = \frac{150 \text{ feet}}{11.3 \text{ seconds}} \times 0.6818 = 9 \text{ mph}$$

### 2. Effective Swath Width

Effective swath width is the area covered by the sprayer during operation. In broadcast spraying (figure 1), the swath width is equal to nozzle spacing. In banding spraying (figure 2), swath width is equal to the treated band. In direct spraying (figure 3), swath width is equal to the row spacing divided by the number of nozzles per row.

Let's work out a few examples:

- In a direct application, sugarcane is planted in 72-inch rows, and 2 nozzles are used per row to direct spray solution to those plants, what is the effective swath width?
  - ◇ **Answer:** Effective swath width will be the row spacing divided by the number of nozzles per row. In this case,  $\frac{72 \text{ in}}{2}$  will yield an effective swath width of 36 inches.

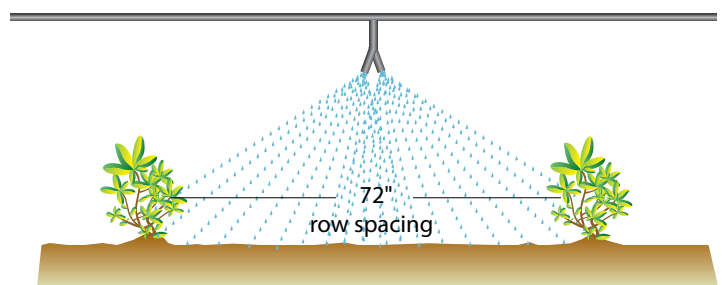

# Broadcast Spraying

SW = 18"

- The swath width is equal to nozzle spacing.

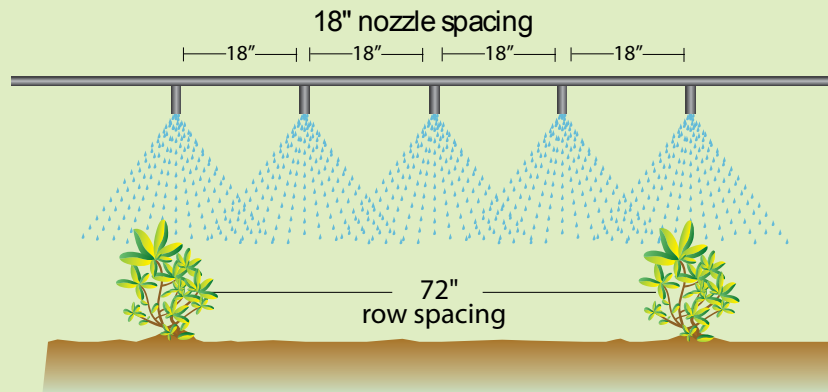

Figure 1

# Banding Spraying

SW = 36"

- The swath width is equal to the treated band.

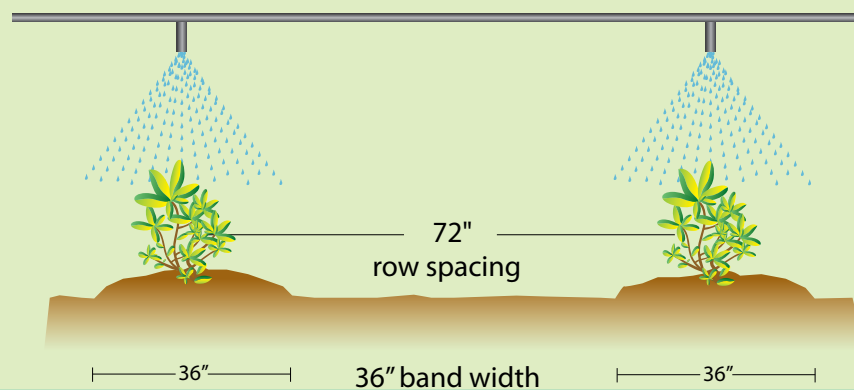

Figure 2

# Direct Spraying

$SW = \frac{72''}{2} = 36''$

- The swath width is equal to the row spacing divided by the number of nozzles per row.

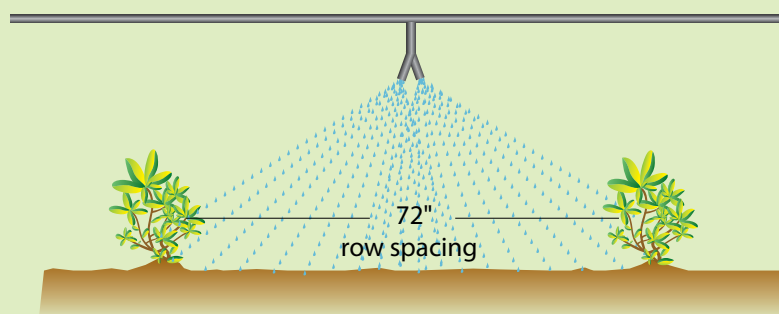
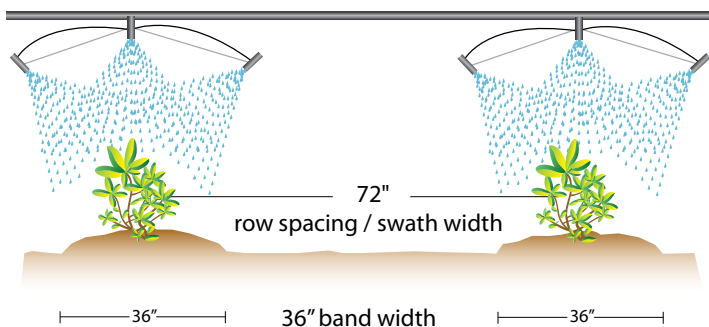

Figure 3

- In herbicide application in sugar cane, 3 nozzles are directed to the plants, the row spacing is 72 inches, but the spray is directed only to 36 inches. What is the effective swath width?

◇ **Answer:** This is a case of direct and band application mixed together. Since 3 nozzles are directed to the plants, only the banded portion is being sprayed. The effective swath width will be  $\frac{36}{3}$  or 12 inches.



Flow numbers from nozzle

We can use this relationship to find nozzle flow information at a different pressure setting given that we know flow information at a particular pressure.

Let's work out an example:

- What is the flow of an 11004 when subjected to a pressure of 60 PSI?

◇ **Answer:** An 11004 will deliver 0.4 gallons per minute at 40 PSI. To find out the volume delivered at 60 PSI, let's use the equation:

$$\frac{0.4}{Q_2} = \sqrt{\frac{40}{60}}$$

The volume at 60 PSI is equal to 0.49 gallons per minute.

Good calibration techniques demand that we measure flow of all nozzles and compute an average flow per minute for the entire boom. Any nozzle delivering more or less than 5% of the average flow of the boom should be discarded and replaced.

Let's work out an example:

- An average flow of 0.385 gallons per minute was calculated. The boom is equipped with 11004 nozzle tips. What are the maximum and minimum values beyond which nozzles should be replaced?

### 3. Nozzle Flow

It is very important to check nozzle flow to be sure that they are

- Free of foreign objects and obstructions
- Within the operating flow range defined by the manufacturer.

Before collecting flow information from the nozzles, clean all strainers and eliminate all foreign materials from the nozzles. Be sure that you have the same type of nozzle in the entire boom. One of the most common mistakes is to find different nozzles, or sometimes nozzles with different orifice sizes alongside the boom. Check nozzles for uniformity of flow. Usually nozzles are encoded with numbers that inform their angle of spray and flow at 40 PSI of pressure. Therefore, an 11004 nozzle produces a spray angle of 110 degrees and delivers 0.4 gallons per minute at a pressure of 40 PSI. Of course, both spray angle and volume are pressure-dependent. The relationship between pressure and flow can be described by the following equation,

$$\frac{Q_1}{Q_2} = \sqrt{\frac{P_1}{P_2}}$$

- ◇ **Answer:** Nozzles delivering plus or minus 5% of the boom mean value should be replaced. In this case, a mean value of 0.385 gallons per minute yield values of {0.365, 0.404}. (Simply multiply the average flow by 0.95 and 1.05 to find the lower and upper limits). Nozzles that are delivering less than 0.365 gallons per minute or more than 0.404 gallons per minute should be discarded and replaced.

## 4. Operating Pressure

The operating pressure affects the flow of liquid through the nozzles. Increasing pressure will increase nozzle flow, although this relationship is not linear. Nozzle manufacturer's catalog brings information on the required pressure in order to achieve the desired application rate. Be sure that your pressure gage is working properly. Have them checked and replaced if necessary at your local dealer.

## Putting It All Together

Finally, after checking all necessary components it is time to calibrate the sprayer. There are a few different methods to follow for sprayer calibration, but we will concentrate in the two most commonly used. Regardless of the method you choose to follow, a few basic principles are involved in the calibration process, they are:

1. Find the information about the application, i.e., volume to be applied, effective swath width, rate of active ingredient per area, etc.



2. Calibrate the sprayer's speed.



3. Use the VOLUME or the AREA method to calculate the correct output of the nozzles.



4. Using clean water only, measure volume of several nozzles per unit of time.



5. If the volume collected is not correct, increase or decrease pressure.



## 1. Volume Method

In the volume method, we start with the desired application rate (GPA), ground speed (MPH) and effective swath width (W). We then need to find the proper volume (GPM) to be delivered by the nozzles at the desired operating pressure. We use the following equation:

$$\text{GPM} = \frac{\text{GPA} \times \text{W} \times \text{MPH}}{5940}$$

Let's work out a few examples:

- In a field broadcast application of 10 gallons per acre (GPA), speed was measured to be equal to 9.7 miles per hour (MPH) and effective swath width is 40 inches (W). What is the needed nozzle flow to achieve the desired application rate?

◇ **Answer:** Applying the formula,

$$\text{GPM} = \frac{10 \times 40 \times 9.7}{5940} = 0.653$$

Therefore a nozzle tip delivering 0.653 gallons per minute is needed to achieve the desired application rate.

To adjust the nozzle properly, fill the sprayer with water and spray at a desired initial operating pressure (i.e. 40 PSI) for a specified time. Collect spray using a graduated receptacle. It is recommended to collect spray from several different nozzles to obtain a representative boom sample. Increase or decrease the system's pressure until the volume collected is equal to the desired value.

- In a banding application, a desired rate of 15 gallons per acre (GPA) is to be applied. Effective swath width is 18 inches (W) and speed was measured to be 7 miles per hour (MPH). What is the needed nozzle flow to achieve the desired application rate?

◇ **Answer:** Applying the formula,

$$\text{GPM} = \frac{15 \times 18 \times 7}{5940} = 0.318$$

Therefore a nozzle tip capable of delivering 0.318 gallons per minute is needed to achieve the desired application rate.

- In a direct application, 3 nozzles are used to direct spray over 36-inch bands in 72-inch sugar cane plants. The desired application rate is 10 gallons per acre (GPA). Speed is 8.5 miles per hour (MPH). What is the needed nozzle flow to achieve the desired application rate?

◇ **Answer:** This is a direct application because 3 nozzles are used to direct spray to the plants and it is also a banded application because only 36 inches are being treated of a total of 72 inches. The effective swath width is  $\frac{36}{3} = 12$  inches. Using the formula,

$$\text{GPM} = \frac{10 \times 12 \times 8.5}{5940} = 0.171$$

A nozzle tip capable of delivering 0.171 gallons per minute is needed in this direct application.

## 2. Area Method

In the area method we first need to find out a suitable distance to collect spray from the nozzles. This distance will vary according to the effective swath width (W). Refer to the following table to find the distance needed.

- Measure the distance found in Table 1 in the field to be sprayed, or in a field with similar terrain conditions.
- With the usual tractor gear arrangements, record the time needed to cover the marked distance. Repeat this process at least three times.
- At a stationary position, start spraying water through the nozzles. Using a graduated receptacle collect the volume sprayed during the same amount of time recorded during the speed calibration. Collect volume from several nozzles.
- The amount of water collected in ounces, represents the application rate in gallons per acre.

Table 1. Effective swath width and distance needed for sprayer calibration.

Effective Swath Width (W) (in)	Distance (ft)
12	340
14	291
16	255
18	227
20	204
22	185
24	170
26	157
28	146
30	136
32	128
34	120
36	113
38	107
40	102
44	93
48	85
54	76
58	70
60	68
66	62
68	60
70	58
72	57

### Let's work out an example:

- Broadcast application of 15 gallons per acre (GPA). Effective swath width is 40 inches. Distance needed for speed check is 102 feet (found in Table 1). Distance is marked in the field and time spent to cover 102 feet recorded. Process is repeated 3 times. Average time needed to cover 102 feet is calculated as 8.1 s. Sprayer is then turned on and volume is collected during 8.1 s with a graduated receptacle. The collection process is done 3 to 5 times using different nozzles in the boom. An average flow of 12 ounces is collected. Since desired application rate is 15 GPA, the pressure

needs to be increased to increase flow. After pressure is increased, a new volume collection is made in 5 nozzles during 8.1 s. The average volume collected is 15 ounces. The application rate is then set for 15 GPA.

## Mixing Examples

Often mixing the correct amount of chemicals in the tank is as difficult as calibrating the sprayer. A few examples are given here to help understanding these procedures.

### Example 1.

- An 8-row planter at a speed of 5mph is equipped with 1 nozzle per row, and 2, 200-gallon saddle tanks. The volume flow of the nozzle is 0.281 gallons per minute. The band to be treated has width of 14 inches. Row spacing is 30 inches. The chemical concentrate has 3 lbs/gallon and an application rate of 1.25 lbs/acre is need. Concentrate is sold in 2.5-gallon containers. The field to be sprayed has 50 acres. Find out what amount of concentrate is needed and the tank mixture.

We can rearrange the GPM formula to find the application rate needed (GPA).

$$GPM = \frac{GPA \times W \times MPH}{5940}$$

Becomes

$$GPA = \frac{GPM \times 5940}{W \times MPH}$$

Then,

$$GPA = \frac{0.281 \times 5940}{14 \times 5} = 23.8$$

The application rate is 23.8 gallons per acre. The field has 50 acres, but we are treating only 14 of every 30 inches. The total solution amount is  $\frac{23.8 \times 50 \times 14}{30} = 555.3$  gallons. An application rate of 1.25 lb/acre is recommended, the total product

needed is  $\frac{1.25 \times 50 \times 14}{30} = 29.1$  lb. Since the chemical concentrate has 3 lb per gallon,  $\frac{29.1}{3} = 9.7$  gallons are needed. From a total of 555.3 gallons, 9.7 gallons are chemical concentrate and the remaining 545.6 gallons are just water. The ratio of water to chemical is  $\frac{545.6}{9.7} = 56.2$ . For every gallon of chemical concentrate, 56.2 gallons of water are needed, totaling 57.2 gallons. In a 400-gallon tank,  $\frac{400}{57.2} = 7$  gallons of concentrate are needed and  $400 - 7 = 393$  gallons of water.

### Example 2.

- Eight oz/ac of an herbicide are recommended at a solution rate of 10 gal/ac. The sprayer tank has 500-gallon capacity and the field has 175 acres.
  - ◇ How much product is needed?
  - ◇ How much water is needed?
  - ◇ The tank mixture ratio.

We need 8 oz per acre. Total field area is 175 acres. Total product needed is  $\frac{175 \times 8}{128} = 10.9$  gallons. Remember that there are 128 ounces in 1 gallon. We're going to apply 10 gallons per acre in 175 acres, so the solution total is 1,750 gallons. Since 10.9 gallons are herbicide, the total amount of water is  $1,750 - 10.9 = 1,739.1$  gallons of water. The ratio water/herbicide is  $\frac{1739.1}{10.9} = 159.5$ . For every gallon of herbicide, 159.5 gallons of water are needed, totaling 160.5 gallons. For a 500 gallon tank, the ratio is  $\frac{500}{160.5} = 3.1$  gallons of herbicide and 496.9 gallons of water.



## Specific Gravity Examples

Since solutions are not pure water, attention has to be given to the specific gravity of the mix. Nozzle catalogs bring information on nozzle flow based on spraying water. If the solution has a specific gravity different from the water's, misapplication will occur. Specific gravity is the solution's density when compared to water density. It is calculated using the following formula.

$$SG = \frac{\text{Mass (lb)}}{\text{Volume (gal)}} \div 8.34$$

Water has specific gravity of 1 (water weighs 8.34 lbs per gallon). For products with other specific gravity values, a conversion factor has to be applied. To calculate a conversion factor, weigh a known volume of the solution and calculate its specific gravity. The conversion factor (CF) is

$$CF = \sqrt{SG}$$

Table 2 brings values of several specific gravities and their corresponding conversion factors.

Table 2. Different solutions' weight, their specific gravity and conversion factor.

Solution's Weight (lb/gal)	Specific Gravity (SG)	Conversion Factor (CF)
7	.84	.92
8	.96	.98
8.34 <sup>a</sup>	1.00	1.00
9	1.08	1.04
10	1.2	1.10
10.65 <sup>b</sup>	1.28	1.13
11	1.32	1.15
12	1.44	1.20
13	1.55	1.25
14	1.68	1.30
15	1.79	1.38

<sup>a</sup> water.

<sup>b</sup> 28% nitrogen.

### Example:

- A solution containing a mix of different herbicides and adjuvant weighs 7.8 lbs per gallon. Calculate its specific gravity and conversion factor. The nozzle to be used in this application is rated 11004. How much solution it will spray, in gallons per minute?

◇ **Answer:** Calculating the specific gravity for the mixture,

$$SG = \frac{7.8 \text{ lbs}}{1 \text{ gal}} \div 8.34 = 0.935$$

The conversion factor is calculated as

$$CF = \sqrt{0.934} = 0.967 .$$

The nozzle 11004 delivers 0.4 gallons per minute of pure water at 40 PSI. To find out what is the flow of a solution with different specific gravity, the following formula is used,

$$Sol = \frac{\text{Water}}{CF}$$

With a solution which specific gravity is 0.934, it will

$$\text{deliver } \frac{0.4}{0.967} = 0.413 \text{ gal}$$

### Example:

- Application rate of 10 gallons per acre of a solution which weighs 9 lb/ gallon. What nozzle information to use?

◇ **Answer:** A solution with 9 lb/gallon has specific gravity of 1.08 and conversion factor of 1.04 (see Table 2). Applying the formula, the equivalent in water is  $10 \times 1.04 = 10.4$ . The applicator should choose a nozzle size that will supply 10.4 GPA of water at the desired pressure.

## Useful Conversions

### Length

- 1 foot = 12 inches = 30.48 cm
- 1 yard = 3 feet = 36 inches = 91.4 cm
- 1 inch = 2.54 cm = 25.4 mm
- 1 meter = 3.281 ft = 39.37 in = 1.09 yd
- 1 mile = 1,609 m = 5,280 ft

### Area

- 1 acre = 43,560 ft<sup>2</sup> = 0.4047 ha = 4,840 yd<sup>2</sup>
- 1 m<sup>2</sup> = 10.76 ft<sup>2</sup>
- 1 ft<sup>2</sup> = 144 in<sup>2</sup>

### Volume

- 1 pint = 2 cups = 16 fl oz
- 1 gallon = 4 qt = 8 pints = 128 oz = 3.785 liters
- 1 ft<sup>3</sup> = 7.48 gallons
- 1 bushel = 1.245 ft<sup>3</sup>
- 1 m<sup>3</sup> = 35.31 ft<sup>3</sup>

### Weight

- 1 oz = 0.0625 lb = 28.35 g
- 1 lb = 16 oz = 454 g
- 1 kg = 2.205 lb

### Speed

- 1 ft/s = 0.681 mph = 0.304 m/s
- 1 mph = 1.609 km/hr

### Pressure

- 1 PSI (lb<sub>f</sub>/in<sup>2</sup>) = 144 lb<sub>f</sub>/ft<sup>2</sup> = 0.068 atm = 2.31 ft of H<sub>2</sub>O

### Temperature

$$\text{Degrees Celsius (}^\circ\text{C)} = \frac{5}{9} (\text{}^\circ\text{F} - 32)$$

# Calibration Work Sheet

## a. Speed Check:

Distance measured: \_\_\_\_\_ ft.

Time spent: 1. \_\_\_\_\_ s.  
2. \_\_\_\_\_ s.  
3. \_\_\_\_\_ s.  
4. \_\_\_\_\_ s.

Average Time: \_\_\_\_\_ s.

Speed:  $\frac{\text{distance (ft)}}{\text{average time (s)}} \times 0.6818 = \text{_____ mph.}$

## b. Effective Swath Width (W):

To find the effective swath width, follow this simple guide.

1. Is the spray being delivered to the entire area (broadcast)?

Yes                      No

If you answered YES, and it is using just one nozzle (per boom output), the application is a broadcast spraying, and the effective swath width is equal to nozzle spacing. If you are using more than one nozzle per location in a direct spraying, effective swath width will be row spacing (in inches) divided by the number of nozzles.

Record nozzle spacing here: \_\_\_\_\_ inches. This is your effective swath width (W).

2. If treating just a portion of the area (band), record here:

N# of nozzles per band: \_\_\_\_\_

Band Width: \_\_\_\_\_ inches

The effective swath width is going to be the band width divided by the number of nozzles.

$$\text{Effective swath width (W)} = \text{Band width} \div \text{Number of nozzles.}$$

# Calibration Work Sheet for the VOLUME Method

---

---

1. Desired application rate, in GPA: \_\_\_\_\_
2. Effective swath width (W): \_\_\_\_\_
3. Speed (MPH): \_\_\_\_\_

Using the formula below, find out what flow in gallons per minute (GPM) is necessary for each nozzle.

$$\text{GPM} = \frac{\text{GPA} \times \text{W} \times \text{MPH}}{5940}$$

With the sprayer stationary and the aid of a stopwatch, collect flow from several nozzles for a minute and compute an average.

Nozzle 1. Flow per minute is \_\_\_\_\_

Nozzle 2. Flow per minute is \_\_\_\_\_

Nozzle 3. Flow per minute is \_\_\_\_\_

Nozzle 4. Flow per minute is \_\_\_\_\_

Nozzle 5. Flow per minute is \_\_\_\_\_

Average flow per minute is \_\_\_\_\_

If the average flow per minute is less than the desired GPM above, increase pressure. If the flow is greater than the GPM above, decrease the pressure.

# Calibration Work Sheet for the AREA Method

---

---

## Step 1. Write down the desired application rate:

1. Desired application rate, in GPA: \_\_\_\_\_
2. Effective swath width (W): \_\_\_\_\_

## Step 2. Using the effective swath width, consult Table 1 on page 8 and find the distance to be measured.

Distance (found in Table 1): \_\_\_\_\_ feet.

## Step 3. Record the time needed to travel the marked distance, do this at least three times.

Time recorded on first trial \_\_\_\_\_ s

Time recorded on second trial \_\_\_\_\_ s

Time recorded on third trial \_\_\_\_\_ s

Average time needed to complete marked distance \_\_\_\_\_ s

## Step 4. Using a graduated receptacle, collect the volume being delivered by several nozzles (at least four) in ounces. Compute an average value.

Nozzle 1. \_\_\_\_\_ oz.

Nozzle 2. \_\_\_\_\_ oz

Nozzle 3. \_\_\_\_\_ oz

Nozzle 4. \_\_\_\_\_ oz

Average flow \_\_\_\_\_ oz

*The flow in ounces corresponds to the application rate in GPA. If volume is lower than the desired application rate, increase pressure and collect again. If volume is higher, decrease pressure.*

# Mixing Work Sheet

## Step 1. Write down the following information:

- Rate of the chemical to be applied: \_\_\_\_\_ ounces/acre.
- Solution rate to be applied: \_\_\_\_\_ gallons/acre.
- Tank total volume: \_\_\_\_\_ gallons.

## Step 2. Calculate the total area to be treated. If the application is “broadcast,” area treated is equal to total area. If application is “banded”:

$$\text{treated area (ac)} = \frac{\text{band spacing (in)}}{\text{row spacing (in)}} \times \text{total area (ac)}$$

## Step 3. Calculate total chemical needed:

$$\text{chemical needed (gal)} = \frac{\text{rate (item a, step 1)} \times \text{treated area (step 2)}}{128}$$

## Step 4. Calculate total water needed:

$$\text{water (gal)} = \text{solution rate (item b, step 1)} \times \text{treated area (step 2)} - \text{chemical needed (step 3)}$$

## Step 5. Calculate the water/chemical ratio:

$$\text{ratio} = \frac{\text{total water (step 4)}}{\text{total chemical (step 3)}}$$

## Step 6. Calculate tank ratio:

$$\text{tank ratio} = \frac{\text{tank volume (item c, step 1)}}{\text{ratio (step 5)} + 1}$$

## Step 7. Calculate number of tanks needed:

$$n\# \text{ tanks refill} = \frac{\text{solution rate (item b, step 1)} \times \text{treated area (step 2)}}{\text{tank volume (item c, step 1)}}$$

**Final instructions. Fill tank with the amount of chemical (gallons) obtained in step 6 and complete with water.**





**Author:**

Roberto Barbosa, PhD, Assistant Professor  
Department of Biological and Agricultural Engineering

Photos courtesy of USDA Natural Resources Conservation Service and LSU AgCenter

**Visit our Web site: [www.lsuagcenter.com](http://www.lsuagcenter.com)**

**Louisiana State University Agricultural Center**

William B. Richardson, Chancellor

**Louisiana Agricultural Experiment Station**

David J. Boethel, Vice Chancellor and Director

**Louisiana Cooperative Extension Service**

Paul D. Coreil, Vice Chancellor and Director

**Pub. 3057**

**05/08**

Issued in furtherance of Cooperative Extension work, Acts of Congress of May 8 and June 30, 1914, in cooperation with the United States Department of Agriculture. The Louisiana Cooperative Extension Service provides equal opportunities in programs and employment.