

**INSTALLATION**

THE PIPE SECTION (LENGTH TO BE DETERMINED BY EACH SPECIFIC INSTALLATION) CONTAINING BOTH VALVES SHOULD BE PREFABRICATED IN A SHOP. A TYPICAL INSTALLATION WILL REQUIRE A PIPE SUPPORT AT SOME POINT (6' TO 10' FROM END) BETWEEN THE TWO VALVES. IF THE ENTRANCE END OF THE PIPE (INSIDE STRUCTURE OR DIKE) IS RESTING ON UNDISTURBED EARTH THE MAIN LENGTH OF PIPE WILL BE RESTING ON VARYING DEPTHS OF NEW FILL. IF THE FILL IS NOT UNIFORMLY AND WELL COMPACTED BELOW THE PIPE, A SETTLING OF THE PIPE WILL OCCUR AND COULD CAUSE THE SAFETY VALVE TO BIND. IN ADDITION TO GOOD COMPACTION OF EARTH BELOW PIPE, A PROVISION ON THE SUPPORT SHOULD BE PROVIDED ALLOWING THE DISCHARGE END OF PIPE TO BE LOWERED IF NECESSARY, TO REVERSE THE STRESS ON THE VALVE SECTION.

IT IS SUGGESTED THAT, WHEN FABRICATING EITHER THE VERTICAL SAFETY OR BUTTERFLY VALVES, A SHORT SECTION OF PIPE BE USED, LENGTH NOT TO BE LESS THAN THE DIAMETER OF THE PIPE. THIS SIMPLIFIES FIELD INSTALLATION TOO: A) TWO BUTT WELDS, B) CLAMPING WITH BANDS (AS SHOWN) OR C) BOLTING TOGETHER OF A CONTINUOUS FLANGE (NOT SHOWN).

**OPERATION**

SLIDING VALVES CAN BE OPERATED EITHER HYDRAULICALLY OR MANUALLY (LEVER).

THE TWO VALVES SHOULD NOT BE OPERATED WITH THE SAME HYDRAULIC POWER SOURCE. ONE MANUALLY AND ONE HYDRAULICALLY OPERATED VALVE WILL PROVIDE GREATER ASSURANCE OF "SHUT-OFF" IN CASE OF POWER SOURCE FAILURE.

**HORIZONTAL VALVE**

THE HORIZONTAL END LOADING VALVE WILL BE OPERATED WITH EACH LOAD, THIS COULD CONVENIENTLY BE POWERED BY A HYDRAULIC PUMP DRIVEN BY A TRACTOR, SMALL GAS ENGINE OR ELECTRIC MOTOR.

TWO INCH DIAMETER HYDRAULIC CYLINDERS ARE SUFFICIENT BUT LARGER CAN BE USED.

PUMP CAPACITY OF 3+ GPM AT 1000 PSI IS ADEQUATE, HOWEVER, IF USED WITH A LARGER CYLINDER, OPERATION WILL BE SLOW.

**VERTICAL SAFETY VALVE**

THE SAFETY VALVE, PREFERABLY LOCATED 2' OR MORE BELOW GRADE IN AN ENCLOSED CHAMBER, SHOULD BE MANUALLY OPERATED AS SHOWN WITH A LEVER.

THE INITIAL OPENING OF THE VERTICAL SAFETY VALVE (WITH NO PRESSURE DOWNSTREAM OF VALVE) WILL BE MOST DIFFICULT. ONCE PRESSURE HAS EQUALIZED ACROSS VALVE, VALVE SHOULD SLIDE FREELY.

COARSE BEDDING IN THE MANURE MIGHT CAUSE SOME PROBLEM IN CLOSING THE BUTTERFLY VALVE COMPLETELY - IF THIS OCCURS, REOPENING SLIGHTLY TO LET BEDDING PASS THROUGH WILL ALLEVIATE PROBLEM. THE SAME IS TRUE FOR THE VERTICAL VALVE.

**CONSTRUCTION NOTES**

ALL ANGLE STEEL IS 2" x 2" x 1/4" MILD STEEL.

ALL WELDS ARE CONTINUOUS.

CHECK ALL PIPE FOR ROUNDNESS BEFORE CUTTING ANY MATERIAL. SOME PARTS MAY HAVE TO BE "FITTED".

PIPE WALL THICKNESS IS NOT CRITICAL; PREFERABLY NOT LESS THAN 1/4" WHERE CMP (CORRUGATED METAL PIPE) IS USED, SPECIAL CONNECTIONS, ADAPTATION AND WELDING PROCEDURES WILL BE NECESSARY.

GREASE FITTINGS ARE SHOWN AND SUGGESTED AS A PREVENTIVE MAINTENANCE OPTION. RECOMMENDED GREASING AFTER EACH PERIOD OF USE.

DO NOT USE A CYLINDER WITH LONGER THAN 16" STROKE ON HORIZONTAL VALVE.

MAKE SURE HYDRAULIC CYLINDER "BOTTOMS" INTERNALLY, AND WILL NOT FORCE AGAINST VALVE FRAME WHEN EXTENDED.

CORNER FILL GUSSETS (ITEM NO. 6) IN VERTICAL SAFETY VALVE MUST BE WELDED ALL AROUND AND GROUND IF NECESSARY TO PROVIDE A SMOOTH, FLUSH SURFACE NEXT TO SLIDE VALVE.

**BILL OF MATERIALS**

ITEM	HORIZONTAL VALVE	VERTICAL SAFETY VALVE	
		24"	30"
1. ANGLE - 1/4" x 2" x 2"	18'	24'(1)	30'(1)
2. FLAT STOCK - 3/8" x 1"	6'	8'(1)	10'(1)
3. SLIDE VALVE - 1/4" SHEET	20" x 42"	26" x 33"	32" x 39"
4. CHUTE - 1/4" SHEET	4-8" x 18"	2-3" x 10"	2-3" x 10"
5. VALVE HOLE REINFORCEMENT - 1/4" SHEET	2-3" x 10"		
6. CORNER GUSSETS - 1/4" SHEET		4-12" x 12"(2)	4-15" x 15"(2)
7. END CLOSURE - 1/4" SHEET		24" x 24"(3)	30" x 30"(3)
8. PIPE, 2" + 2 CAPS		31"	37"
9. GREASE FITTINGS		8	8
10. CYLINDER ANCHOR PLATE	3/4" x 6" x 8"		
WELDING ROD EST.	2-3#	3-4#	4-5#

- (1) MORE MAY BE NEEDED IF FRAME IS EXTENDED TO SUPPORT HYDRAULIC CYLINDER
- (2) EACH SQUARE MAKES TWO GUSSETS
- (3) THESE MAY HAVE TO BE SLIGHTLY BIGGER IF PIPE IS NOT ROUND

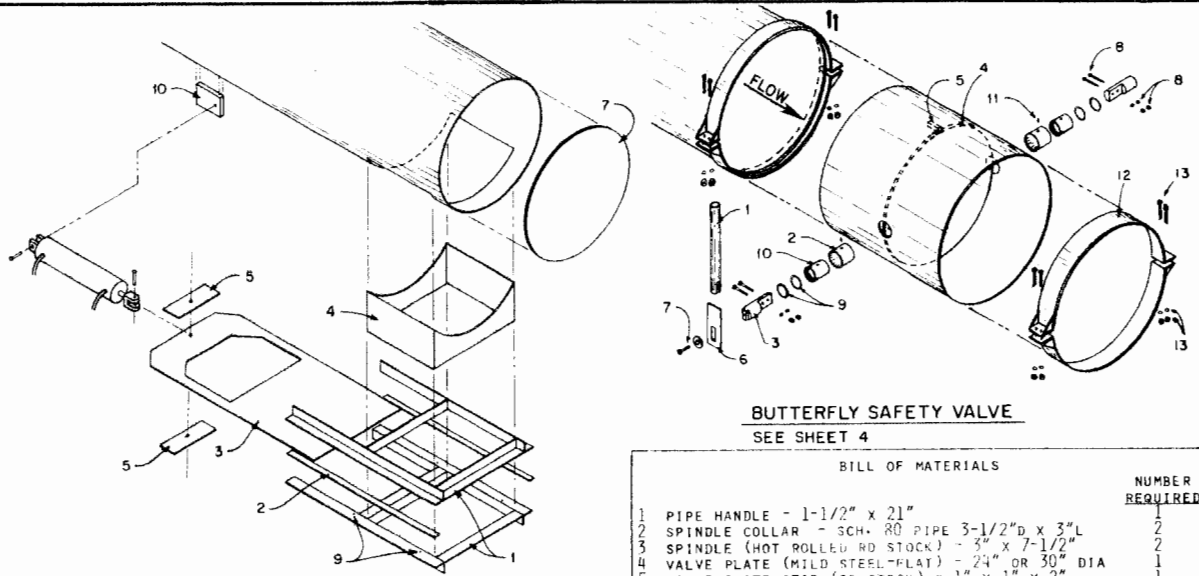

**BUTTERFLY SAFETY VALVE**  
SEE SHEET 4

BILL OF MATERIALS		NUMBER REQUIRED
1	PIPE HANDLE - 1-1/2" x 21"	2
2	SPINDLE COLLAR - SCH. 80 PIPE 3-1/2"D x 3"L	2
3	SPINDLE (HOT ROLLED RD STOCK) - 3" x 7-1/2"	1
4	VALVE PLATE (MILD STEEL-FLAT) - 24" OR 30" DIA	1
5	VALVE PLATE STOP (SQ STOCK) - 1" x 1" x 2"	1
6	HANDLE END (FLAT STOCK) - 1/2" x 3" x 10"	1
7	CAP SCREW - 5/8" NC x 2" AND FLAT WASHER	1 EA
8	BOLTS - 5/8" NC x 2-1/2" W/NUTS AND LOCK WASHERS	4 EA
9	"O" RING - 3/16" x 2-1/2" ID x 3-1/4" OD	4
10	RUSHING (BRASS) - 3-.015" ID x 3-.35" OD x 3" LH	2
11	GREASE FITTING	2
12	BAND (FLAT STOCK) - 1/4" x 5" x 4" (24" PIPE)	4 EA
	1/4" x 3" x 5" (30" PIPE)	4 EA
13	BOLTS - 1/2" NC x 4" W/NUTS AND LOCK WASHERS	8 EA

**HORIZONTAL VALVE**  
SEE SHEETS 2 AND 3

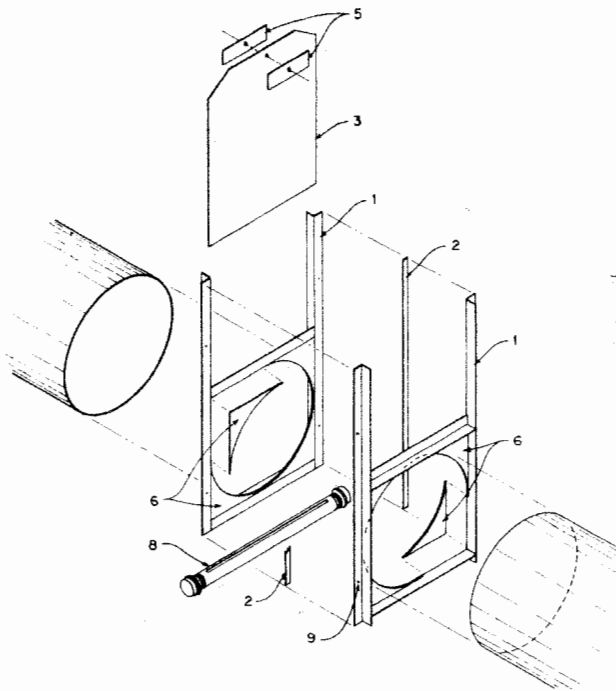

**VERTICAL SAFETY VALVE**  
SEE SHEET 2

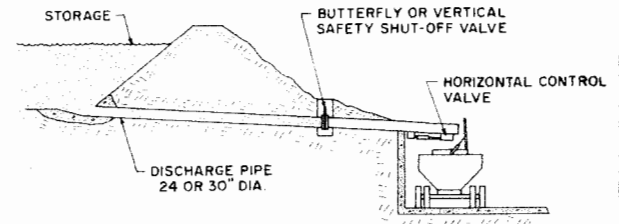

**CROSS SECTION OF GRAVITY LOAD-OUT FROM STORAGE**

**LSU**  
**AgCenter**  
Research & Extension

---

**VALVES FOR GRAVITY MANURE HANDLING**

WV-NY '84	6361	SHEET 1 OF 4
-----------	------	--------------

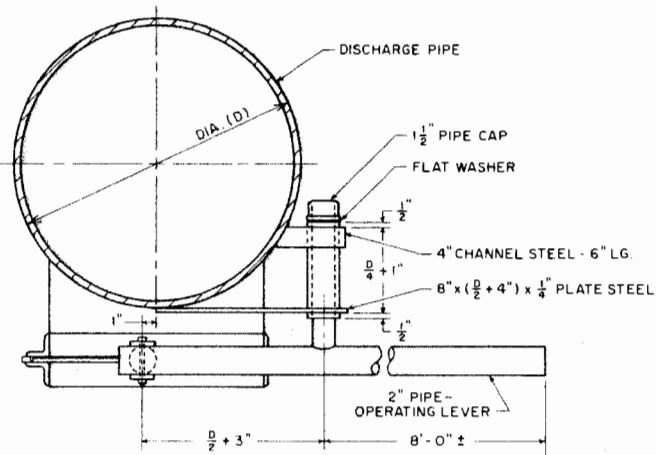

SECTION A-A

SCALE:  $\frac{1}{8}'' = 1''$

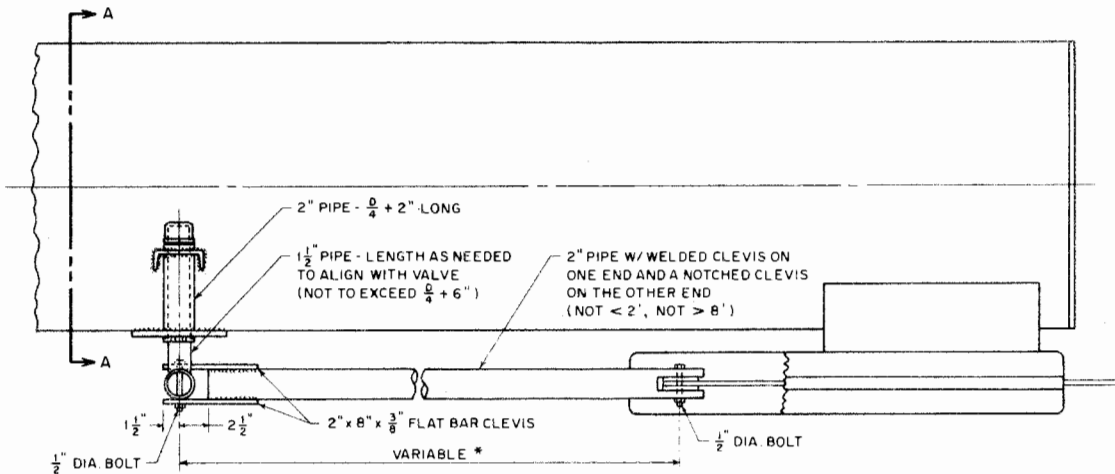
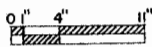

LEVER OPERATED HORIZONTAL VALVE

SCALE:  $\frac{1}{8}'' = 1''$

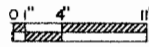

\* 2" OIA. PIPE LENGTH TO BE DETERMINED WHEN VALVE IS IN MID OPEN POSITION AND THE OPERATING LEVER IS  $\perp$  TO THE DISCHARGE PIPE

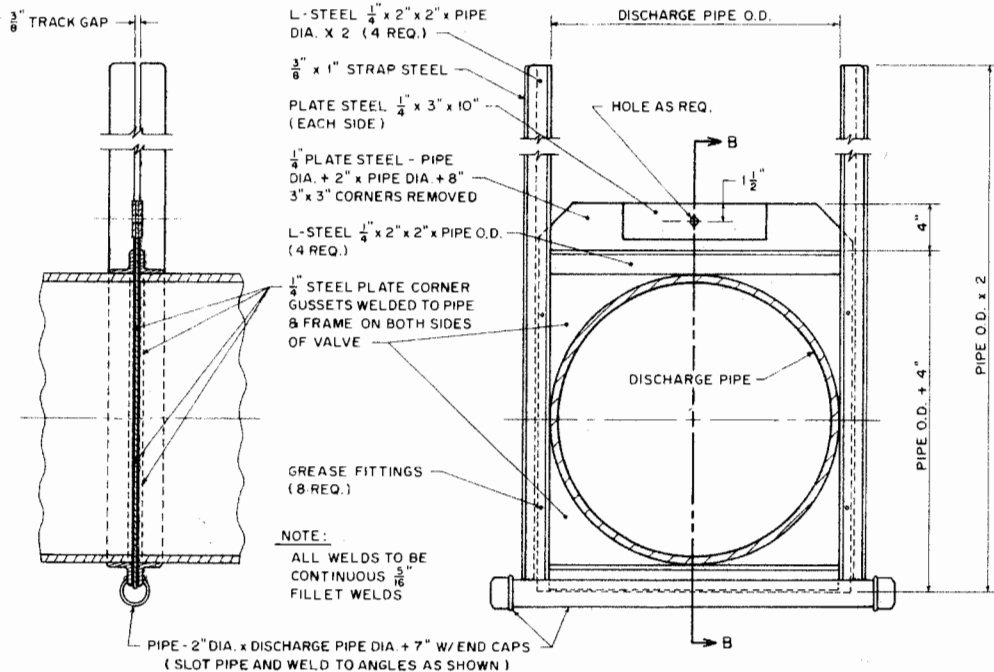

NOTE:  
ALL WELDS TO BE CONTINUOUS  $\frac{5}{16}''$  FILLET WELDS

SECTION B-B

SCALE:  $\frac{1}{8}'' = 1''$

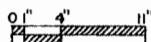

VERTICAL SAFETY VALVE

SCALE:  $\frac{1}{8}'' = 1''$

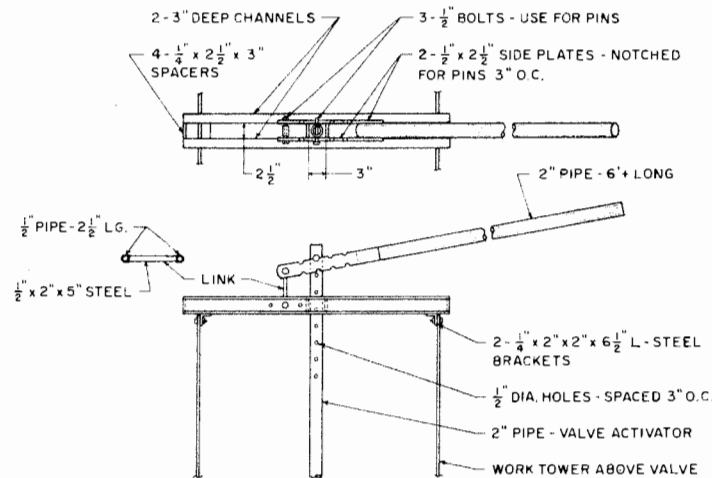
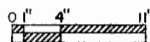

LEVER OPERATOR FOR VERTICAL SAFETY VALVE

NOT TO SCALE



VALVES FOR GRAVITY MANURE HANDLING

WV-NY '83

6361

SHEET 2 OF 4

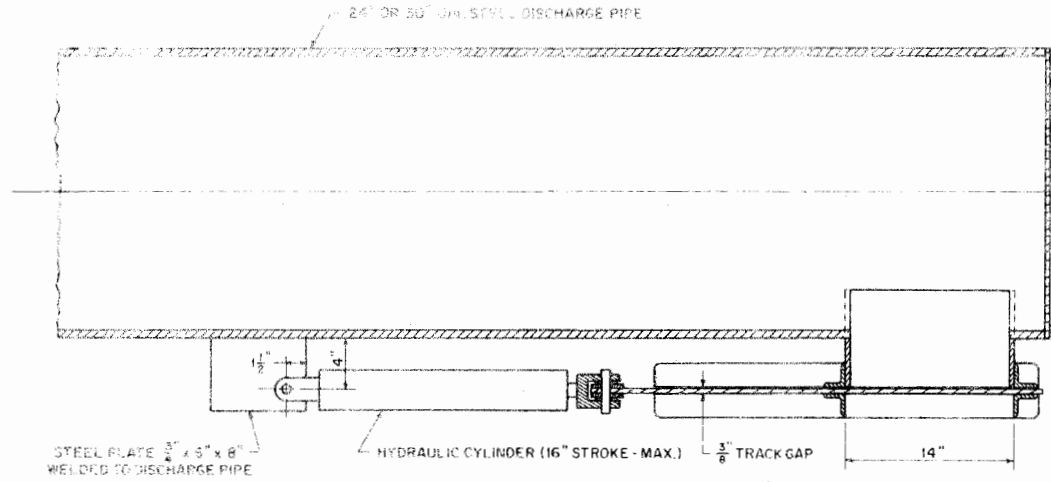

SECTION A-A

SCALE:  $\frac{1}{8}'' = 1''$

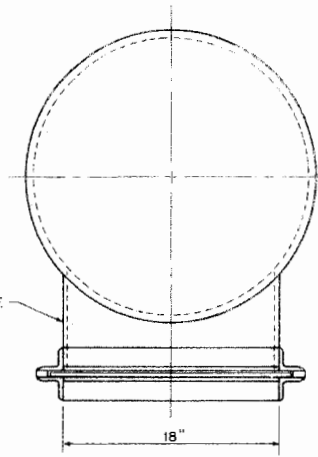

END VIEW

SCALE:  $\frac{1}{8}'' = 1''$

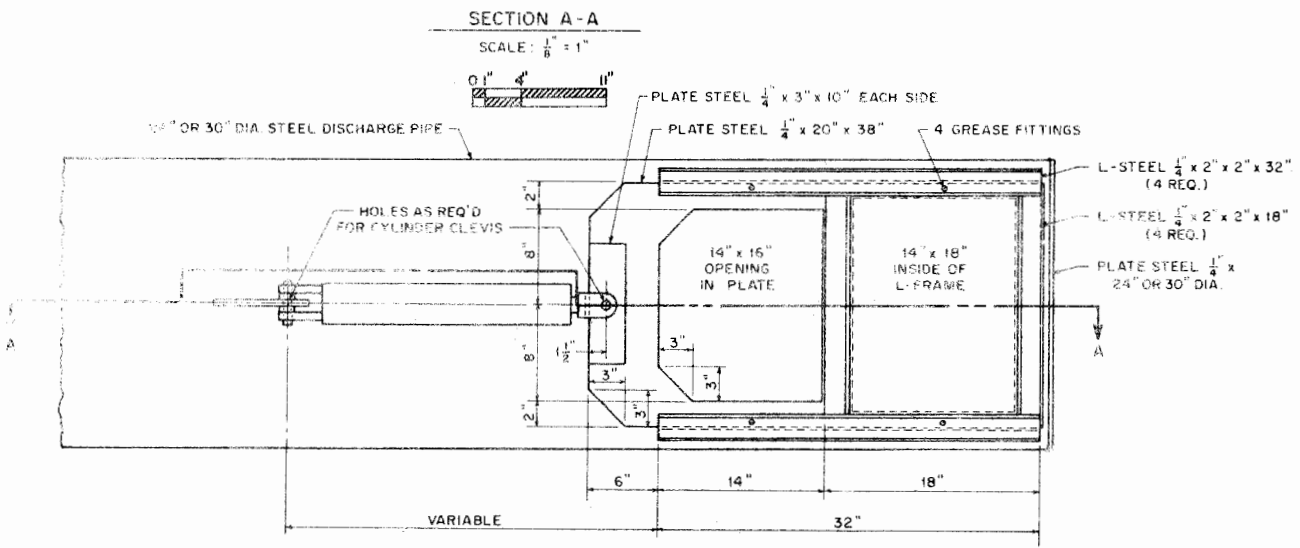

BOTTOM VIEW

SCALE:  $\frac{1}{8}'' = 1''$

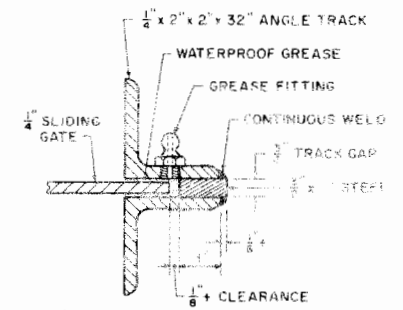

TRACK DETAIL

SCALE:  $\frac{1}{2}'' = 1''$

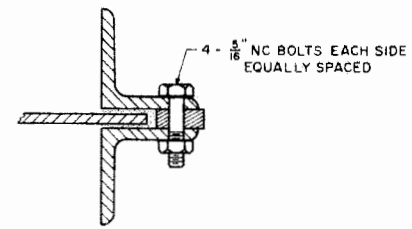

OPTIONAL TRACK DETAIL

SCALE:  $\frac{1}{2}'' = 1''$

NOTE:  
ALL WELDS TO BE CONTINUOUS  $\frac{5}{16}''$   
FILLET WELDS

HORIZONTAL VALVE



VALVES FOR GRAVITY MANURE HANDLING

WV-NY '83 6361 SHEET 3 OF 4

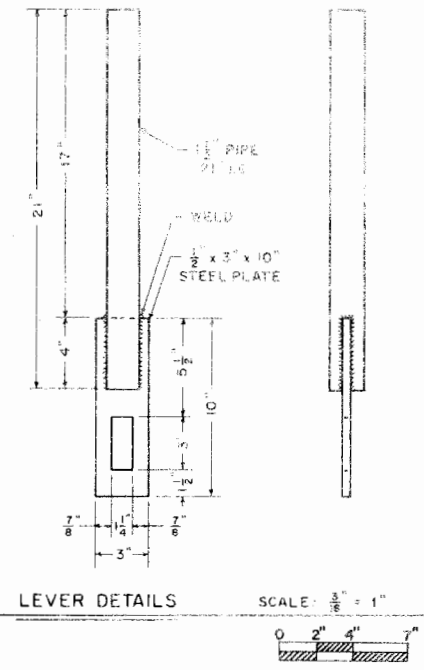
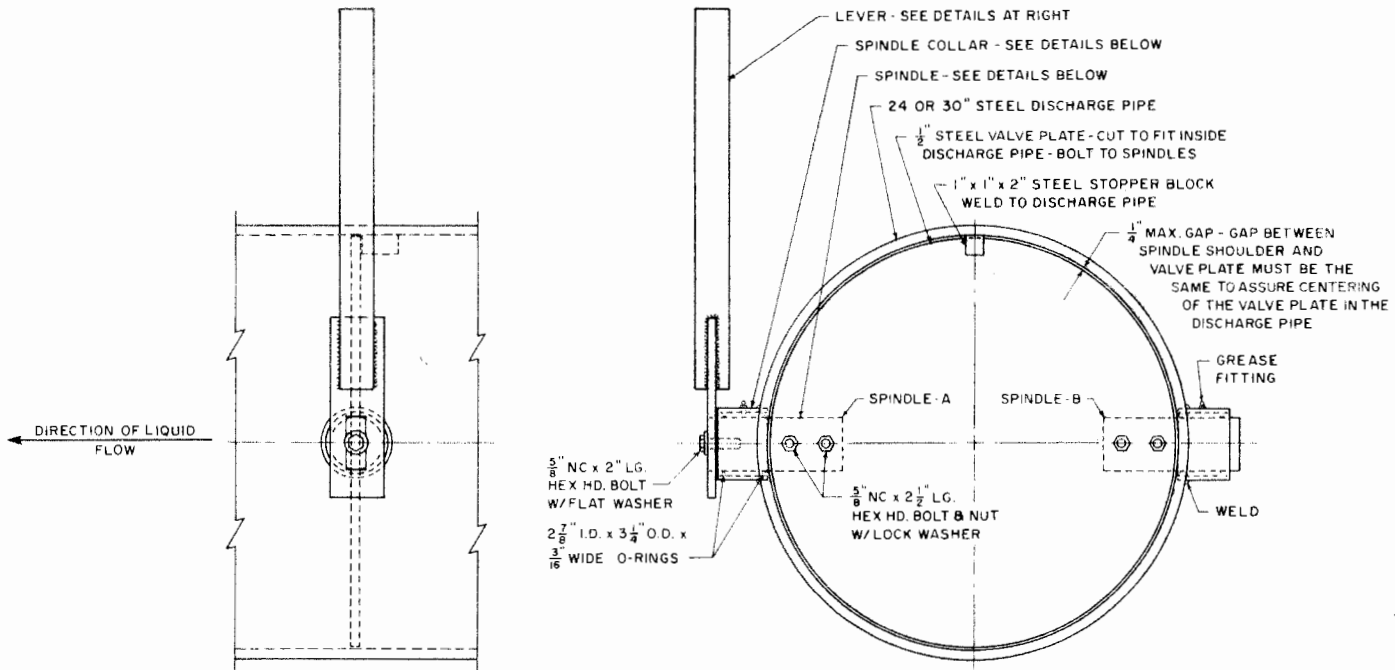

BUTTERFLY SAFETY VALVE ASSEMBLY

SCALE:  $\frac{3}{16}'' = 1''$

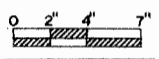

LEVER DETAILS

SCALE:  $\frac{3}{8}'' = 1''$

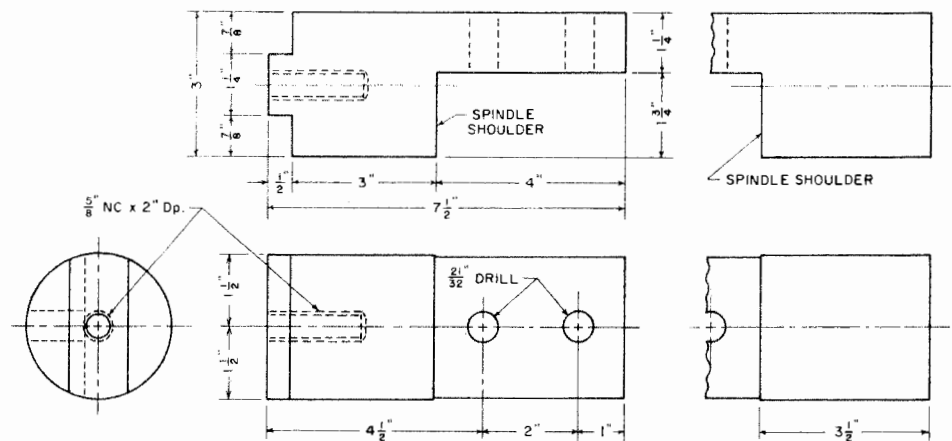
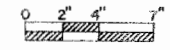

SPINDLE DETAILS - A

SCALE:  $\frac{1}{2}'' = 1''$

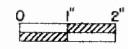

SPINDLE DETAILS - B

SCALE:  $\frac{1}{2}'' = 1''$

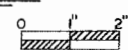

NOTE:  
ALL OTHER DETAILS FOR SPINDLE - B  
SAME AS SPINDLE - A

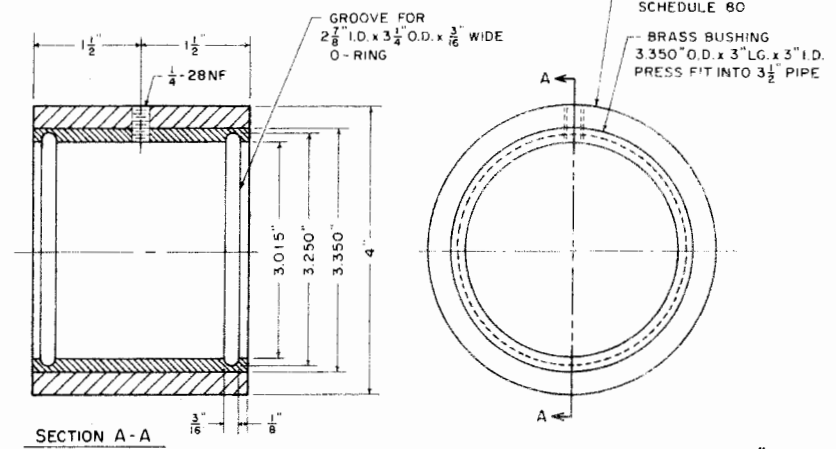

SECTION A-A

SPINDLE COLLAR DETAILS

SCALE:  $\frac{3}{4}'' = 1''$



NOTE:  
TO ALIGN SPINDLE COLLARS - INSERT  
3\"/>

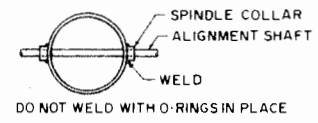

DO NOT WELD WITH O-RINGS IN PLACE



VALVES FOR GRAVITY MANURE HANDLING

## Disclaimer

This site makes available conceptual plans that can be helpful in developing building layouts and selecting equipment for various agricultural applications. These plans do not necessarily represent the most current technology or construction codes. They are not construction plans and do not replace the need for competent design assistance in developing safe, legal and well-functioning agricultural building system. The LSU Agriculture Center, the Mid-West Plan Service, the United States Department of Agriculture and none of the cooperating land-grant universities warranty these plans.